



# MOTION CONTROL EXPERT

- Rotary Damper
- Gas Spring
- Linear Damper
- Latch

---

Delight Your Consumers With Amazing Design



# CONTENTS

1

## Rotary Damper

- Partial Angle Damper
- Barrel Damper
- Gear Damper
- Others



2

## Gas Spring

- Compression Gas Spring
- Lockable Gas Spring



3

## Linear Dampers

- Active Return Linear Damper
- Passive Return Linear Damper



4

## Latch





# CHARACTERISTIC

## GAS SPRINGS

Like a conventional spring, a Gas Spring gives a counterforce in the same direction. But it has flat spring characteristics with a low force increase throughout the stroke.

Gas Springs consist of a tube, a piston, and a piston rod. The tube is filled with inert gas at high pressure, which forces the piston rod to compress or extend. During the compression or extension, the force and velocity are controlled by gas passing through valves in the piston.

A Gas Spring also contains a small amount of oil to reduce the friction of the piston and other parts. The oil also serves to dampen the stroke velocity before full extension or compression and creates a smooth motion.

We need different Gas Springs for most applications. It is because they have various dimensional requirements and need different pre-loads. The pre-loads depend on the weight of the supported objects, like a vehicle's tailgate.

### Gas Spring Stroke Characteristic

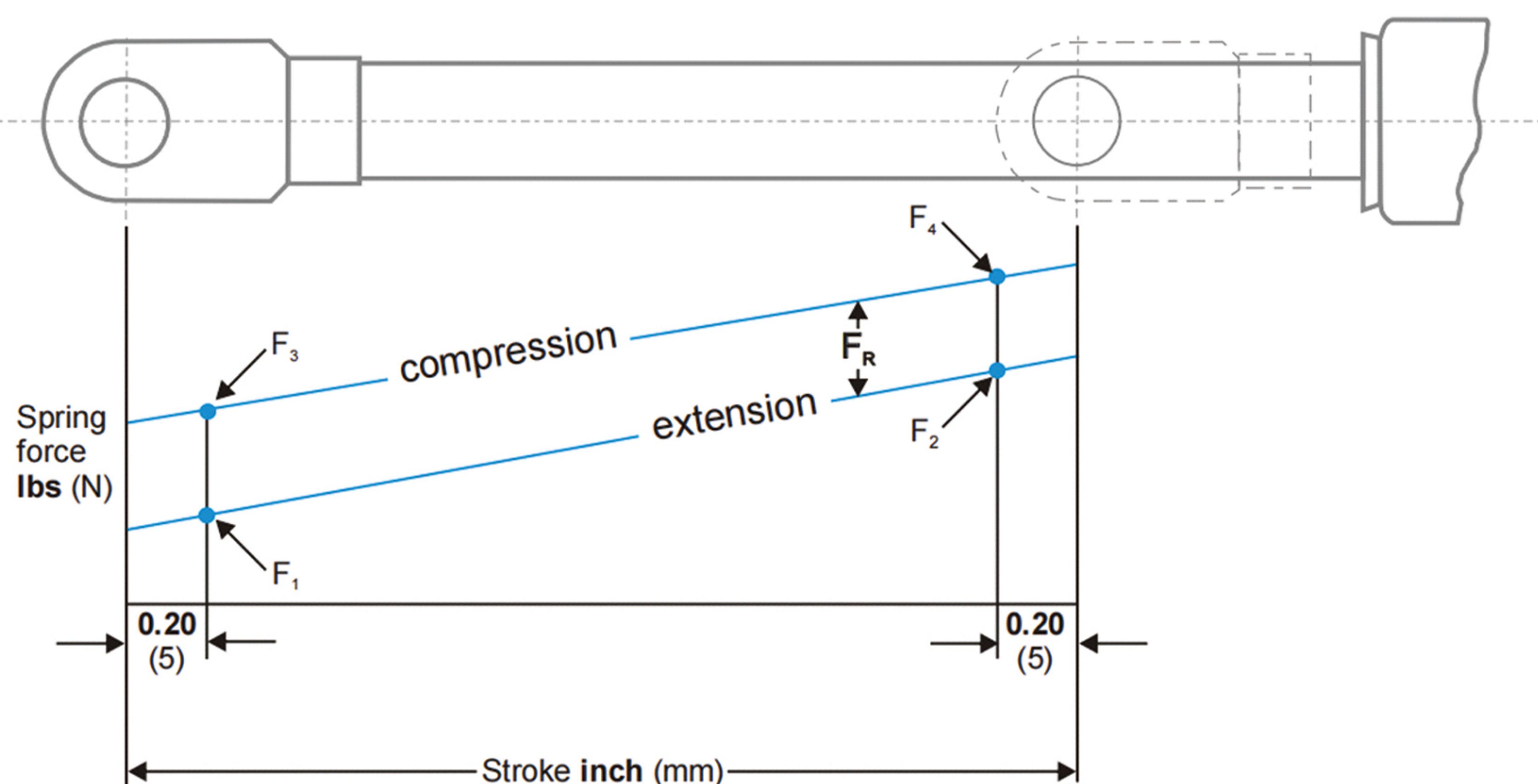



## Calculations And Mounting Guide

Below is a basic calculation that gives an approximation of the minimum required gas spring force for a specified mounting position geometry.

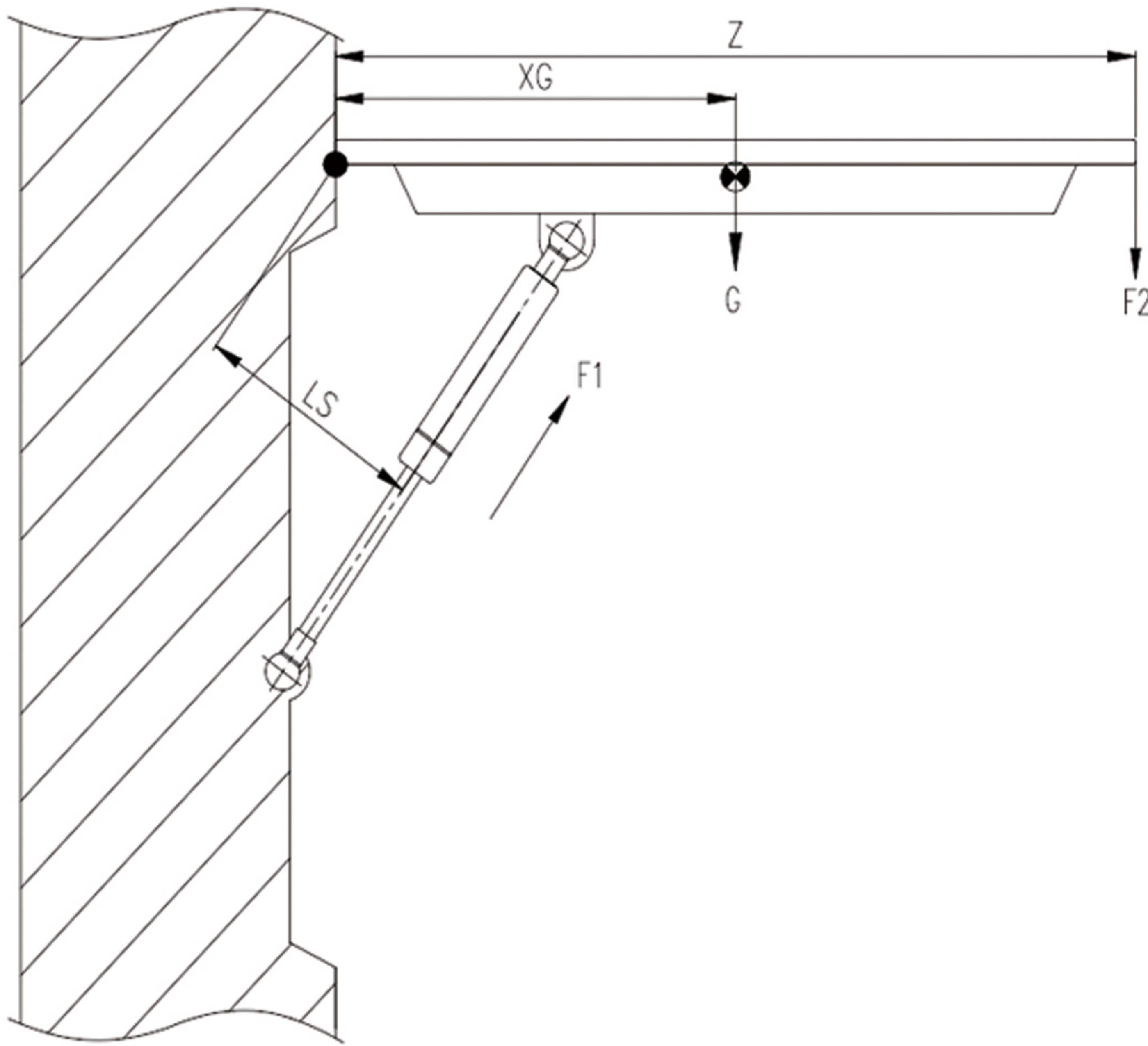

$$F1 = \frac{G \times XG}{LS \times A}$$

**Estimating Gas Spring Force F1 (N)**

**Z** = Length of lid from pivot(hinge) point(mm)

**XG** = Centre of gravity(mm)

**G** = Weight of lid in Newtons (kg x 10)

**LS** = Radius of gas spring force(mm)

**A** = Number of gas springs per application

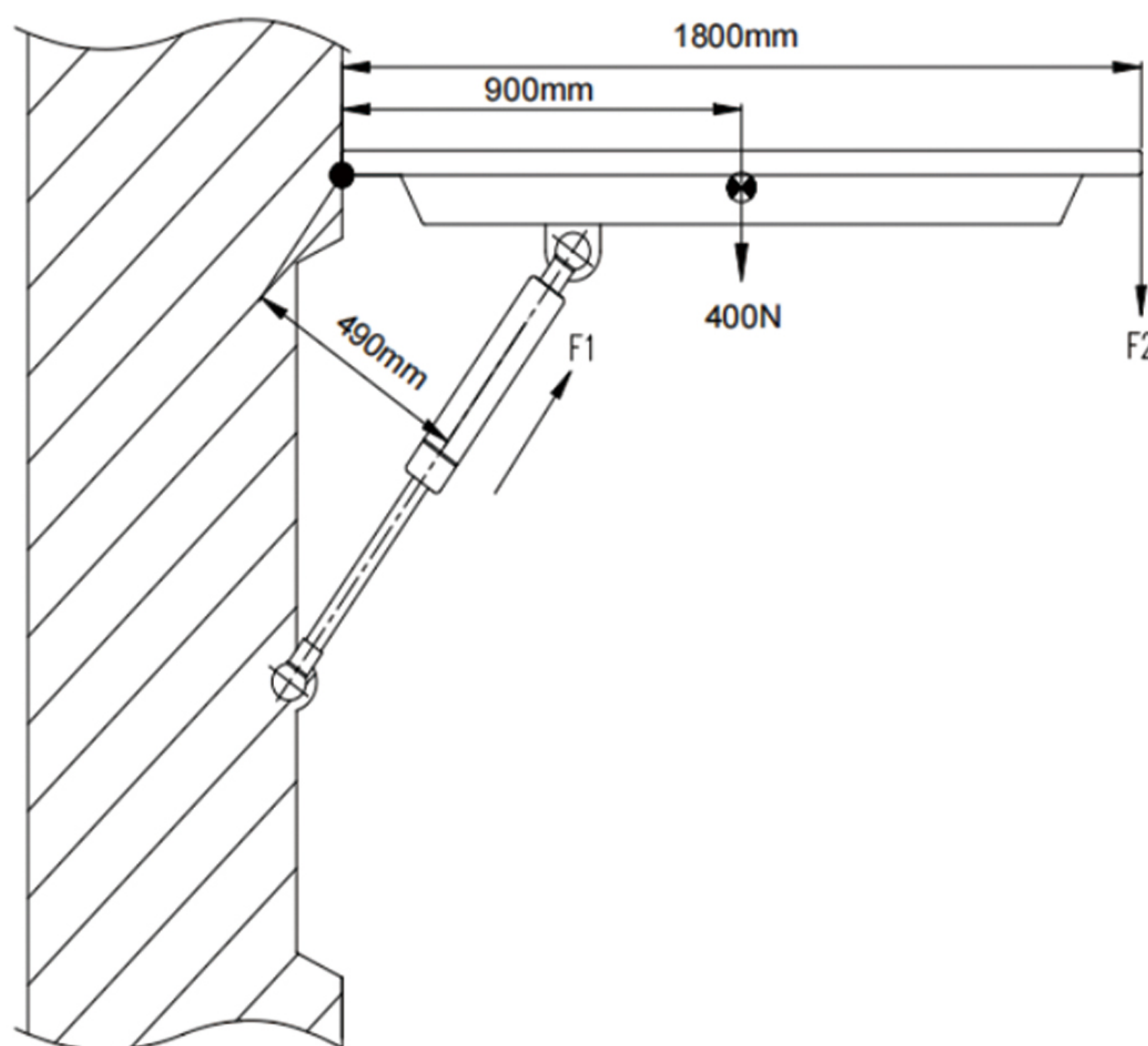

**Example For Estimating Gas Spring**

**Force F1 (N)**

$$F1 = \frac{400N \times 900mm}{490mm \times 2}$$

$$F1 = 367.35N$$

**To estimate the closing effort F2 (N)**

$$F2 = \frac{A \times F1 \times LS}{Z}$$

$$F2 = \frac{2 \times 367.35 \times 490}{1800} = 200N$$



## Compression Gas Spring

- Gas springs are finished with a thread of M6, M8 or M10, for which there is a wide range of end fittings.
- End fittings for compression springs can be found on page 12.
- The piston rod is made of 45# steel, which is treated by QPQ or chrome plating.
- The cylinder body is made of 20# steel and black painted.
- If it is a stainless steel gas spring, the rod and body are made of 316L or 304.

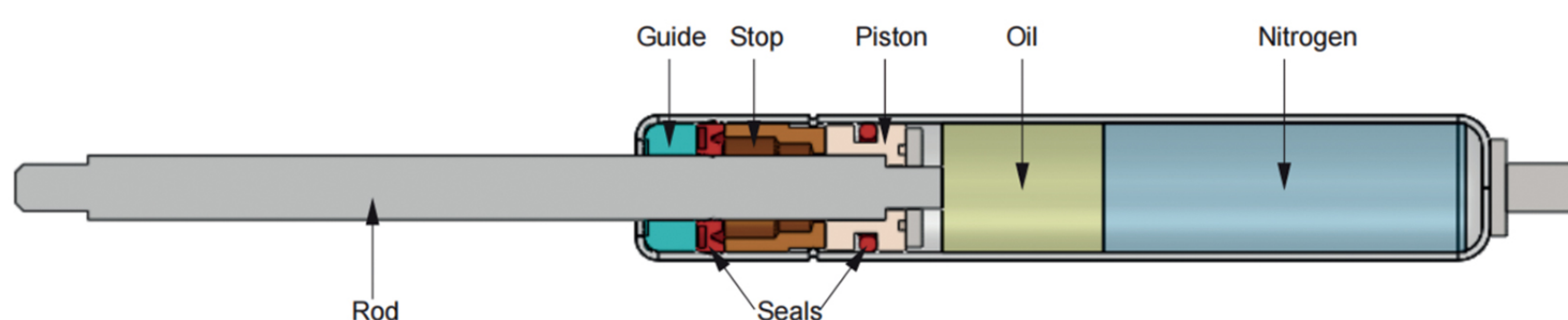

## Gas Spring Application



Automobile



Kitchen Cabinet



Monitor Arm



Recreational Vehicle



Wall Bed/ Tatami



Passenger Luggage Compartment

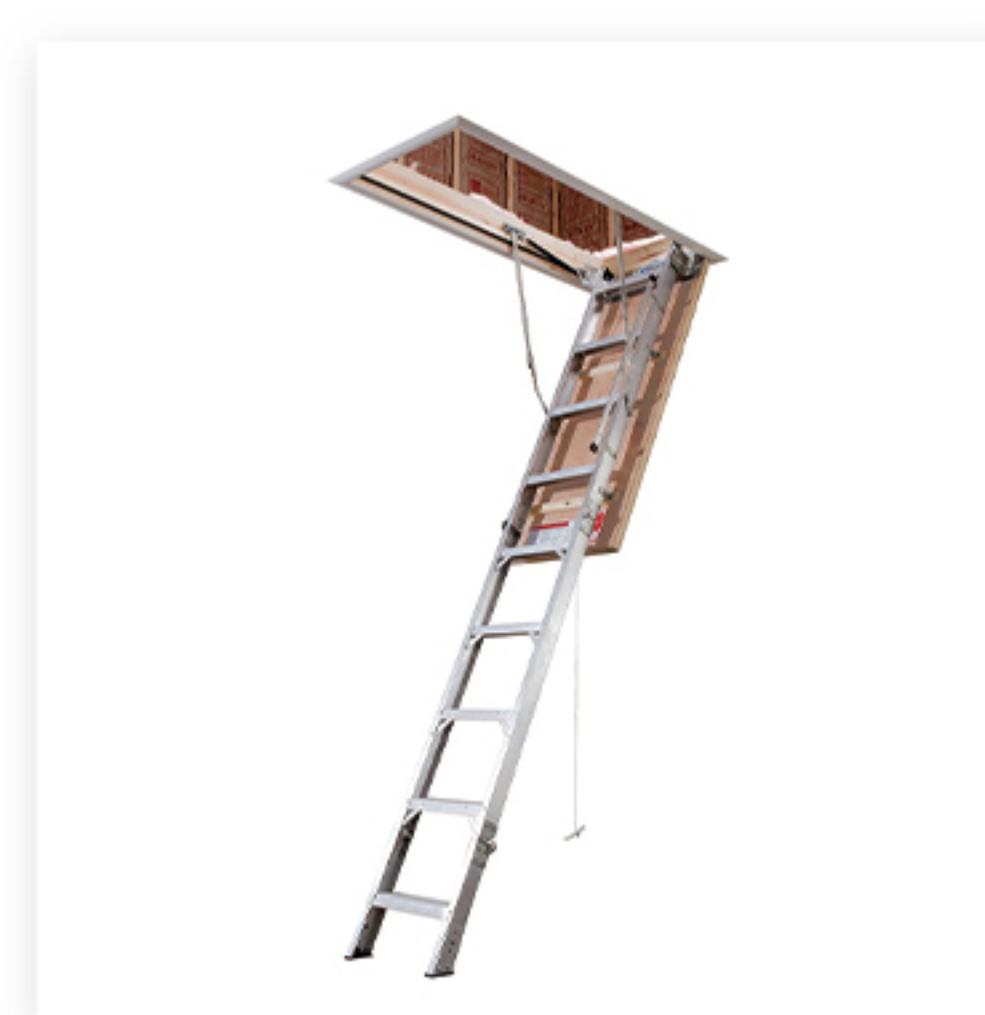

Attic Ladder



Window



Compression Gas Spring **YQ6/15**

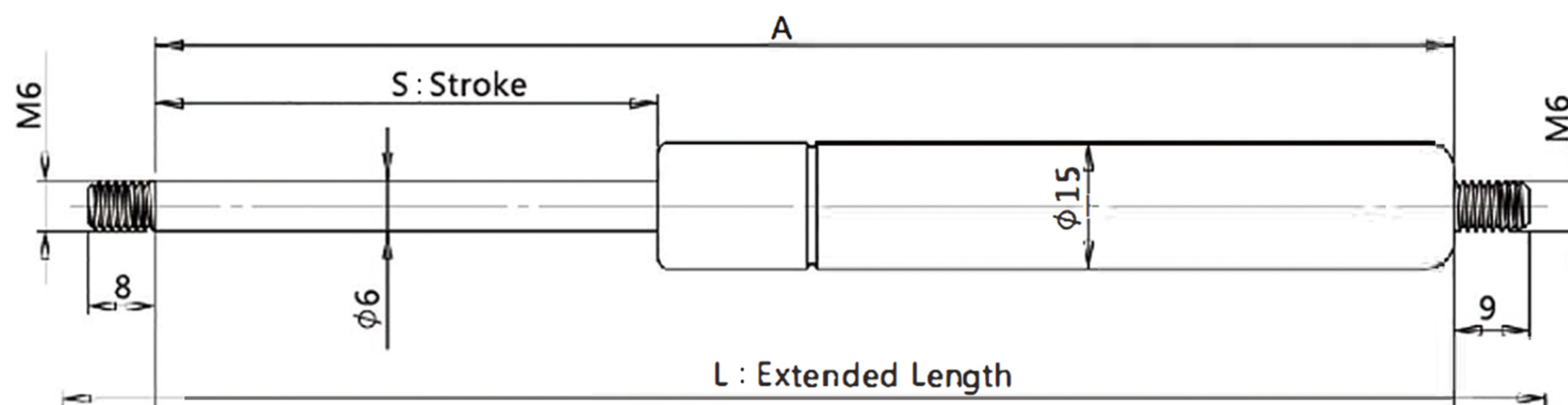

S	A(Min)	Force F1(N)	Ref. NO.
30	91	50-400	YQ6001
35	101		YQ6002
40	111		YQ6003
45	121		YQ6004
50	131		YQ6005
55	141	50-350	YQ6006
60	151		YQ6007
65	161		YQ6008
70	171		YQ6009
75	181		YQ6010
80	191		YQ6011
85	201		YQ6012
90	211	YQ6013	
95	221	YQ6014	
100	231	YQ6015	
105	241	50-300	YQ6016
110	251		YQ6017
115	261		YQ6018
120	271		YQ6019
125	281		YQ6020
130	291		YQ6021
135	301		YQ6022
140	311		YQ6023
145	321		YQ6024
150	331		YQ6025
155	341	50-200	YQ6026
160	351		YQ6027
165	361		YQ6028
170	371		YQ6029
175	381		YQ6030
180	391		YQ6031
190	411		YQ6032
200	431		YQ6033



Compression Gas Spring YQ8/18(19) |

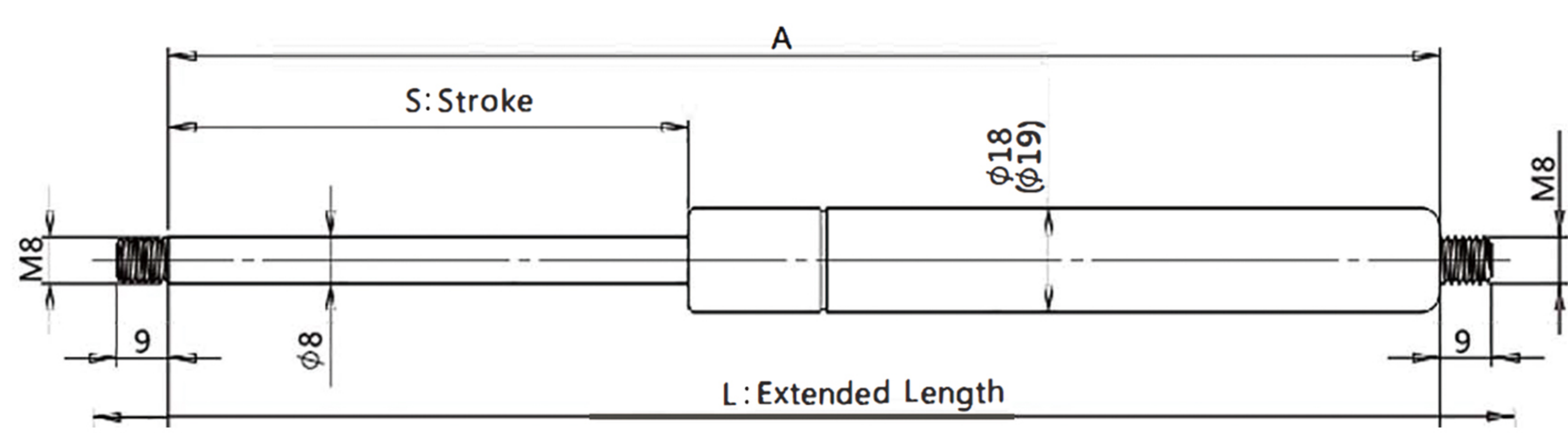

S	A(Min)	Force F1(N)	Ref. NO.
50	141	50-700	YQ8001
60	161		YQ8002
70	181		YQ8003
80	201		YQ8004
90	221		YQ8005
100	241		YQ8006
110	261		YQ8007
120	281		YQ8008
130	301		YQ8009
140	321		YQ8010
150	341		YQ8011
160	361		YQ8012
170	381		YQ8013
180	401		YQ8014
190	421		YQ8015
200	441	YQ8016	
210	461	50-600	YQ8017
220	481		YQ8018
230	501		YQ8019
240	521		YQ8020
250	541		YQ8021
260	561		YQ8022
270	581		YQ8023
280	601		YQ8024
290	621		YQ8025
300	641		YQ8026
320	681	YQ8027	
350	741	50-500	YQ8028
380	801		YQ8029
400	841		YQ8030



Compression Gas Spring **YQ10/ 22**

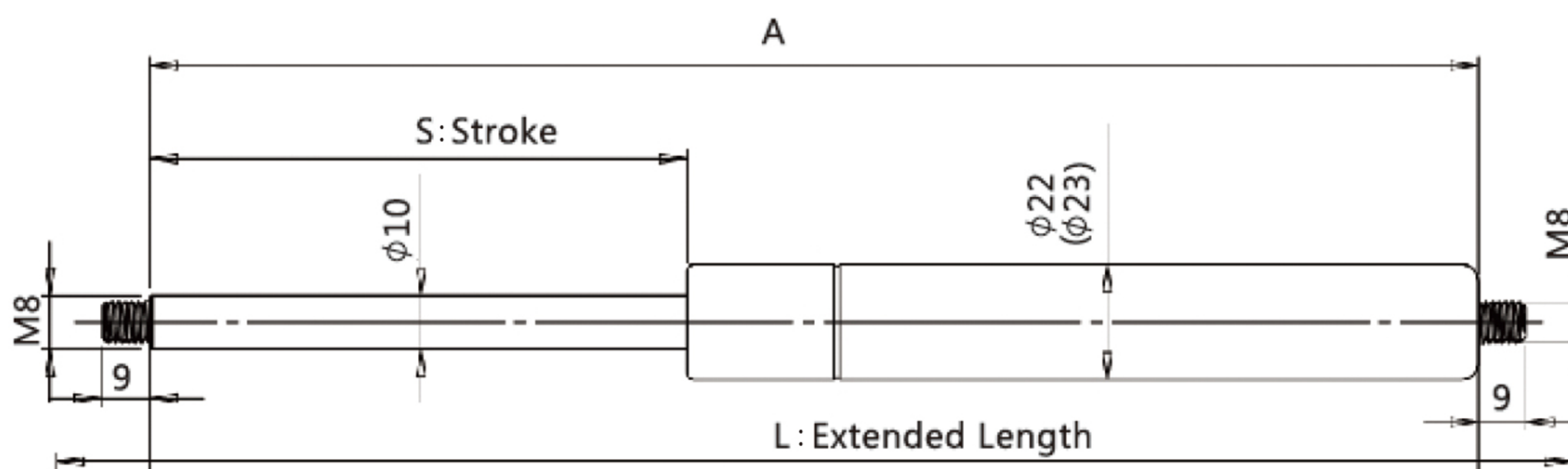

S	A(Min)	Force F1(N)	Ref. NO.
50	145	50-1000	YQ10001
60	165		YQ10002
70	185		YQ10003
80	205		YQ10004
90	225		YQ10005
100	245		YQ10006
110	265		YQ10007
120	285		YQ10008
130	305		YQ10009
140	325		YQ10010
150	345		YQ10011
160	365		YQ10012
170	385		YQ10013
180	405		YQ10014
190	425		YQ10015
200	445	YQ10016	
210	465	50-900	YQ10017
220	485		YQ10018
230	505		YQ10019
240	525		YQ10020
250	545		YQ10021
260	565		YQ10022
270	585		YQ10023
280	605		YQ10024
290	625		YQ10025
300	645		YQ10026
320	685	YQ10027	
350	745	50-700	YQ10028
380	805		YQ10029
400	845		YQ10030



## Compression Gas Spring YQ12/ 25 ~ 14/ 28 |

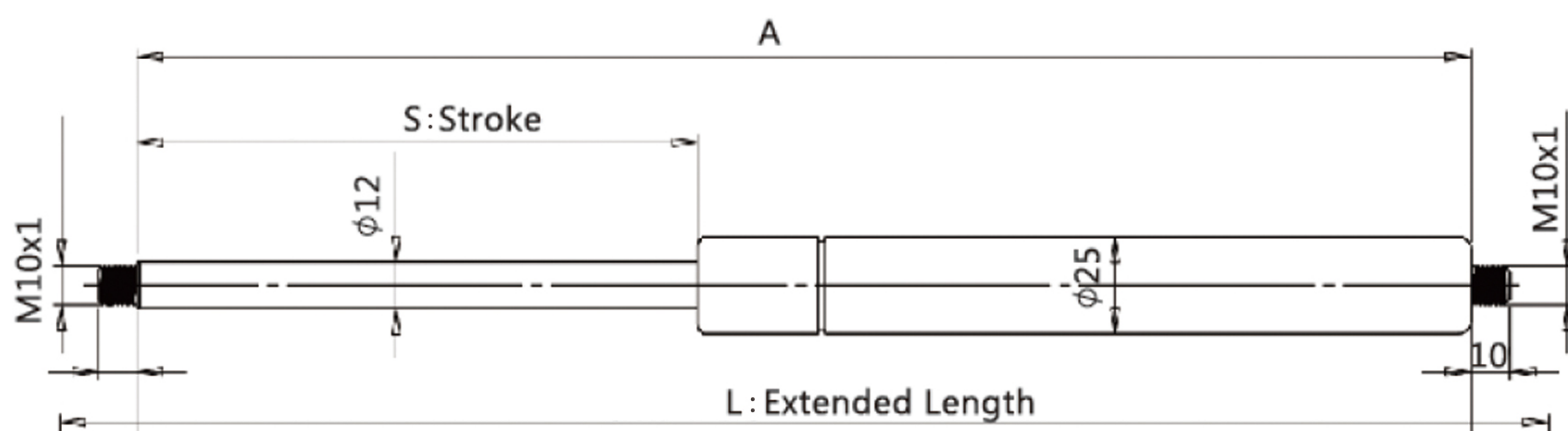

	S	A(Min)	Force F1(N)	Ref. NO.
12/25	100	245	500-1500	YQ12001
	125	295		YQ12002
	150	345		YQ12003
	175	395		YQ12004
	200	445		YQ12005
	225	495		YQ12006
	250	545		YQ12007
	275	595		YQ12008
	300	645		YQ12009
	325	695		YQ12010
	350	745		YQ12011
	375	795		YQ12012
	400	845		YQ12013
	450	895		YQ12014
	500	1045		YQ12015
14/28	100	245	500-2000	YQ14001
	125	295		YQ14002
	150	345		YQ14003
	175	395		YQ14004
	200	445		YQ14005
	225	495		YQ14006
	250	545		YQ14007
	275	595		YQ14008
	300	645		YQ14009
	325	695		YQ14010
	350	745		YQ14011
	375	795		YQ14012
	400	845		YQ14013
	450	895		YQ14014
	500	1045		YQ14015



## Lockable Gas Spring

The lockable gas spring aids the ergonomics and comforts in many applications. With them, you can change the seated or lying position or lift heavy covers easily and precisely. Also, they are used in many other applications.

Our lockable gas springs are able to lock them in any stroke position, whether elastic or rigid. Depending on the pressure medium, this locking feature can be either rigid or elastic. Our special functions offer particular advantages when it comes to convenience and feasibility.

You can choose rigid-locking if the cushioning effect not desired in the locking position. It is suitable for lighter weight applications. These applications need high forces when locked and require no movement.

When the locking function need cushioning effect, elastic locking gas springs are used. Thus, sudden jolting loads can be reduced or even completely avoided.



## Lockable Gas Spring Application



Yacht

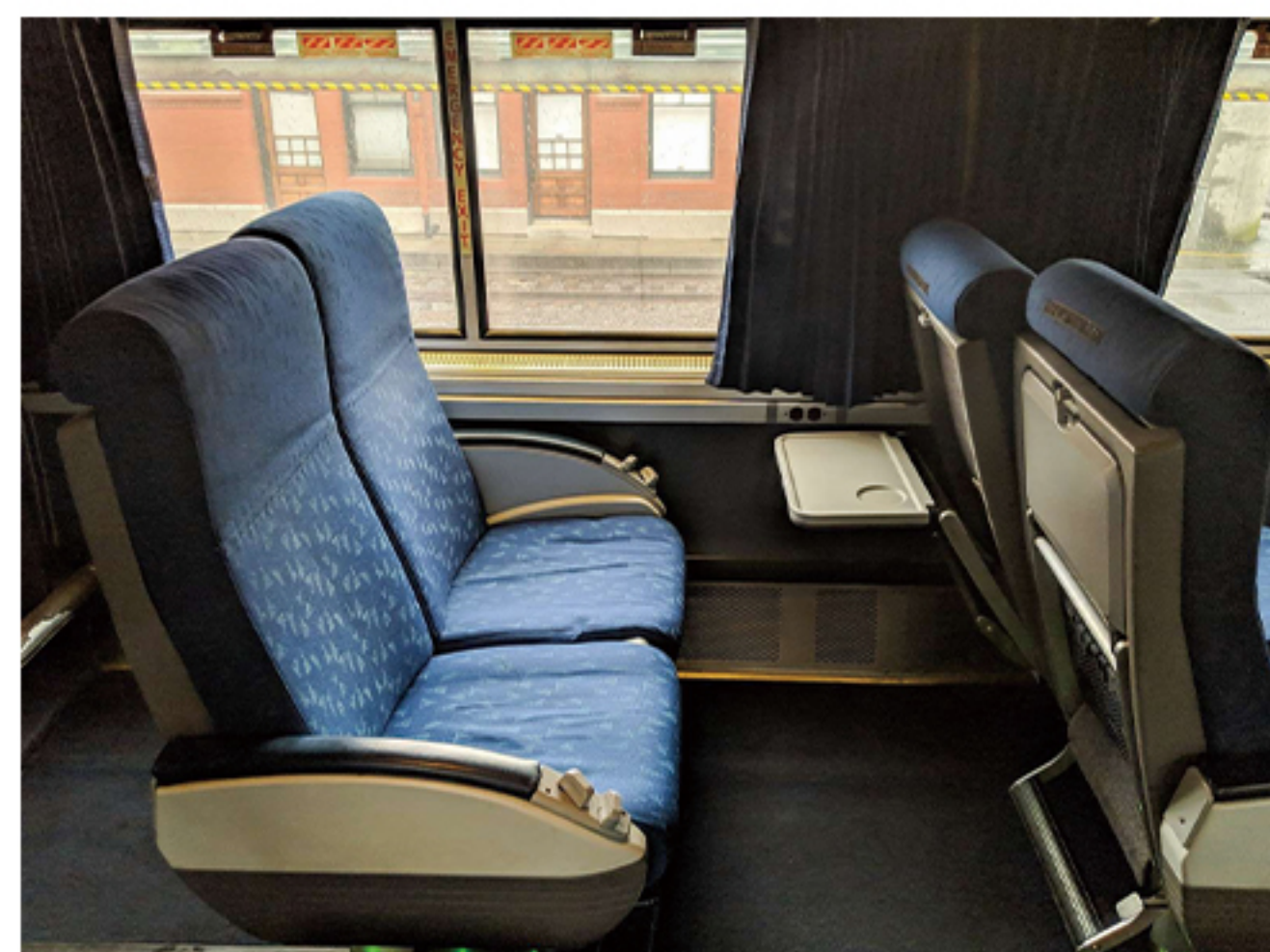

Coach Seat



Sit-stand Desk



Height Adjustable Table



Medical Bed



Multi-Functional Adjustable Recliner



Outdoor Wicker Chaise Lounge Chair



Wheelchair



## Lockable Gas Spring(Rigid)

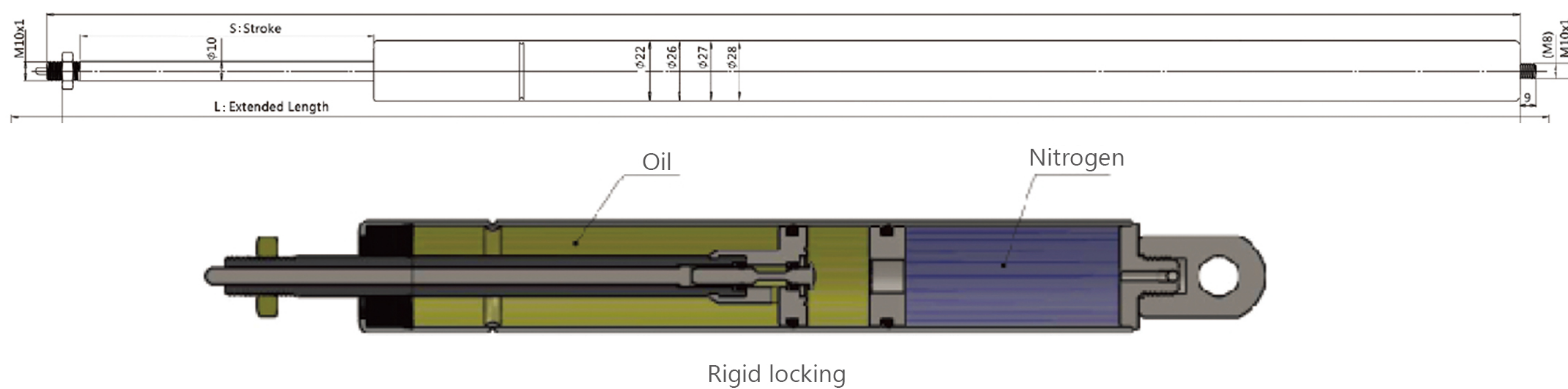

S	A(Min)	Force F1(N)	Ref. NO.
20	138	50-1000N	KQ1001
30	158		KQ1003
40	178		KQ1005
50	198		KQ1007
60	238		KQ1009
70	258		KQ1011
80	278		KQ1013
85	288		KQ1014
90	298		KQ1015
95	308		KQ1016
100	318	KQ1017	
110	358	50-800N	KQ1018
120	378		KQ1019
130	398		KQ1020
140	418		KQ1021
150	438		KQ1022
160	478		KQ1023
170	498		KQ1024
180	518		KQ1025
190	538		KQ1026
200	558		KQ1027
220	618	50-600N	KQ1028
250	678		KQ1029
270	718		KQ1030
300	778		KQ1031
320	818		KQ1032
350	878	50-300N	KQ1033
370	918		KQ1034
400	978		KQ1035
450	1078		KQ1036
500	1178	50-200N	KQ1037



## Lockable Gas Spring(Elastic) |

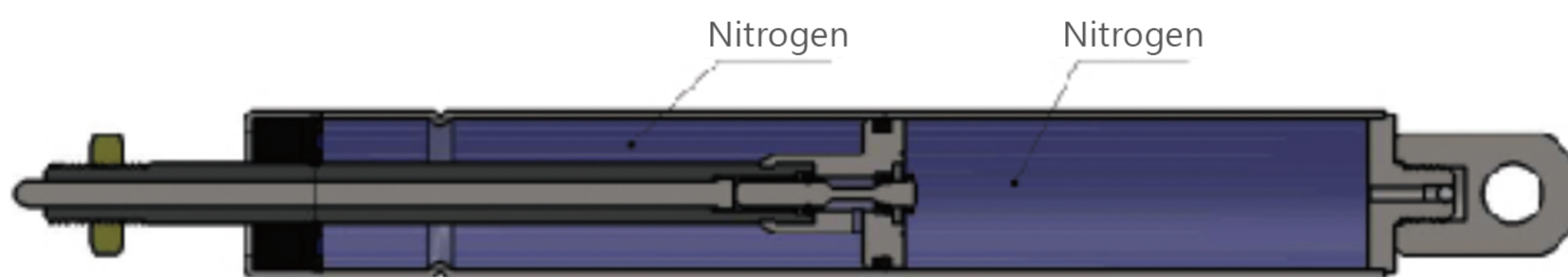
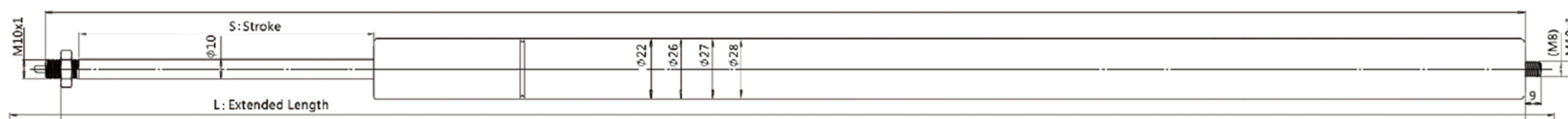

Elastic locking

S	A(Min)	Force F1(N)	Ref. NO.
20	98	50-1000N	KQ2001
30	118		KQ2003
40	138		KQ2005
50	158		KQ2007
60	178		KQ2009
70	198		KQ2011
80	218		KQ2013
85	228		KQ2014
90	238		KQ2015
95	248		KQ2016
100	258	50-800N	KQ2017
110	278		KQ2018
120	298		KQ2019
130	318		KQ2020
140	338		KQ2021
150	358		KQ2022
160	378		KQ2023
170	398		KQ2024
180	418		KQ2025
190	438		KQ2026
200	458	50-600N	KQ2027
220	498		KQ2028
250	558		KQ2029
270	598		KQ2030
300	658	50-300N	KQ2031
320	698		KQ2032
350	758		KQ2033
370	798		KQ2034
400	858		KQ2035
450	958	50-200N	KQ2036
500	1058		KQ2037



## End Fitting

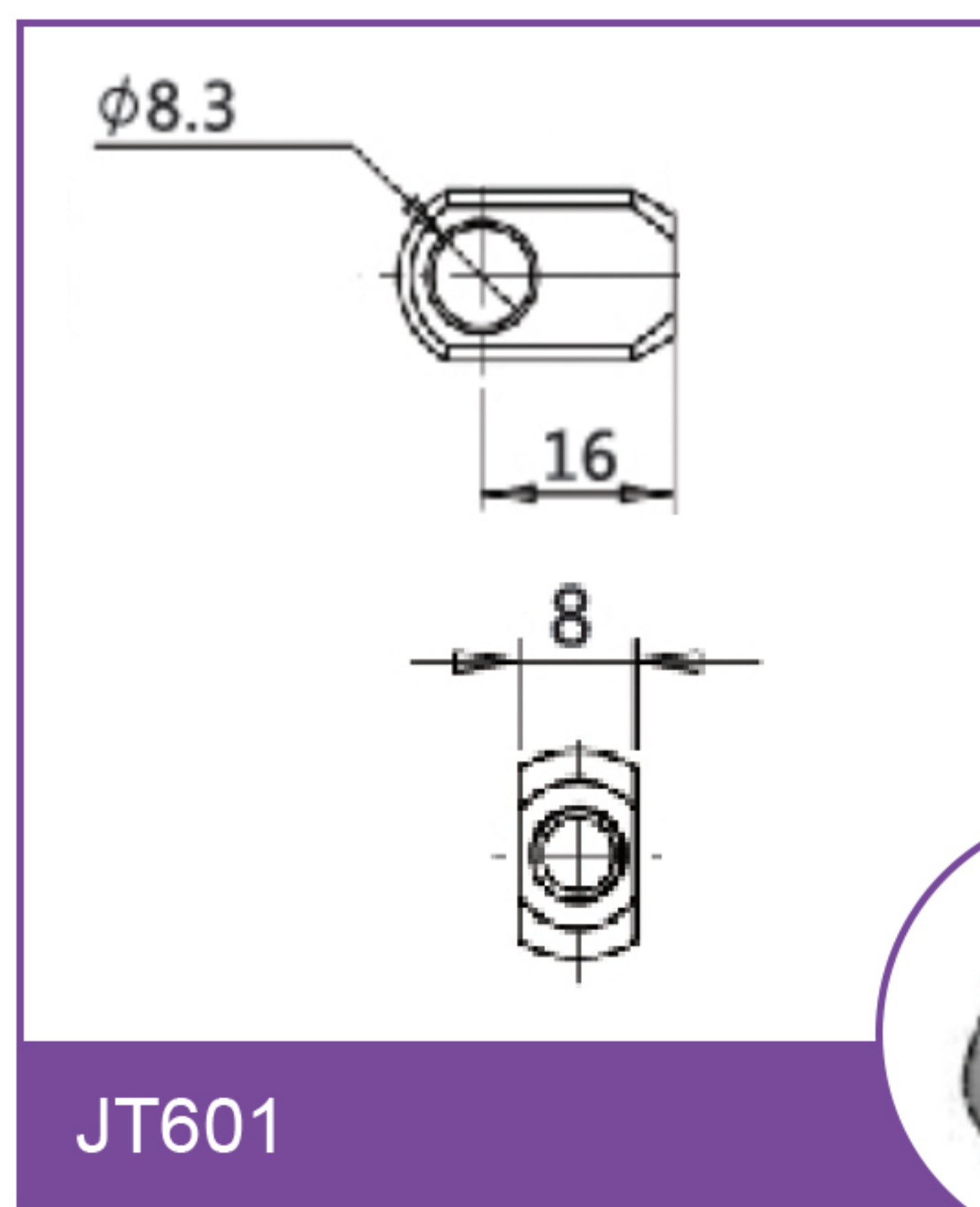

JT601

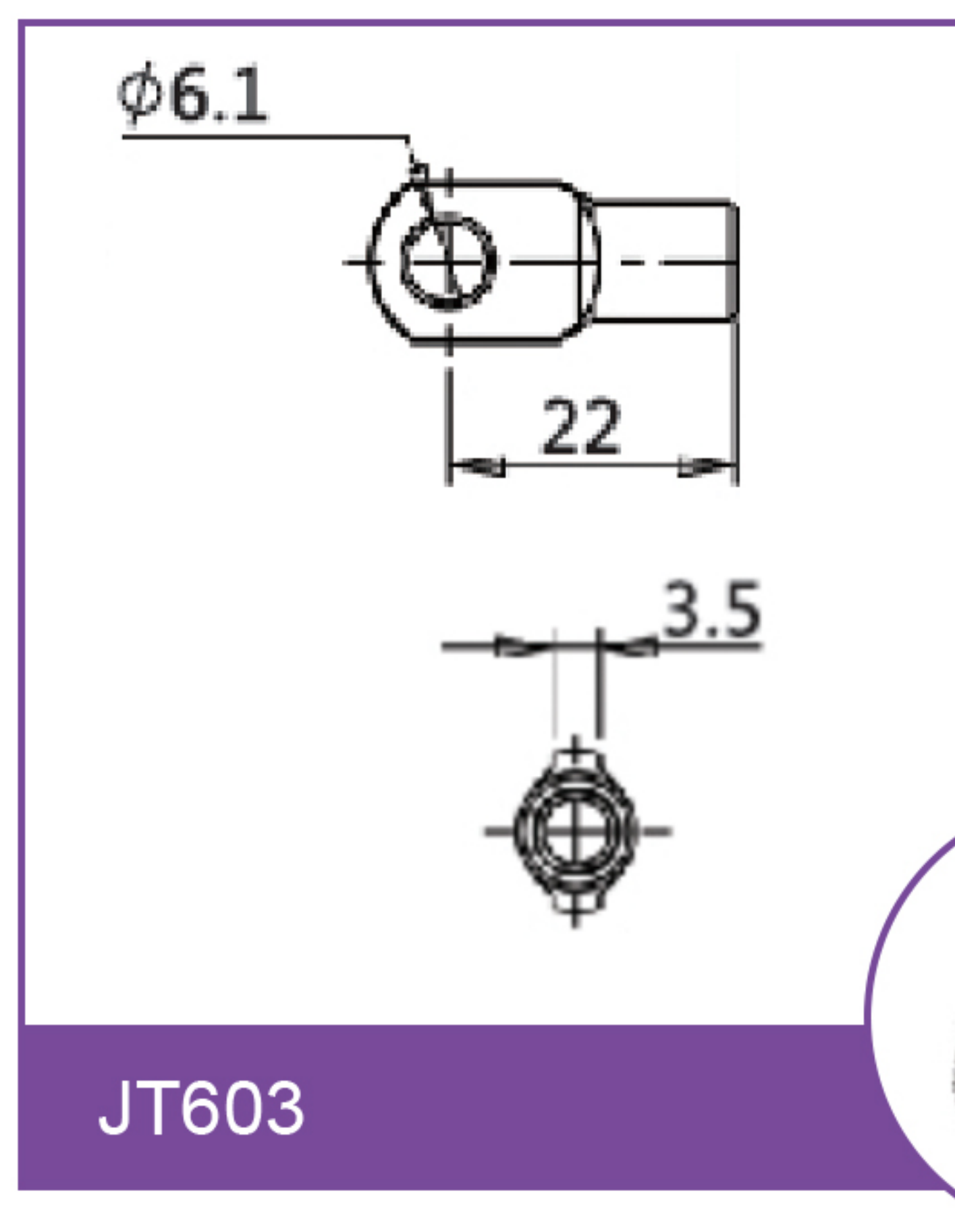

JT603

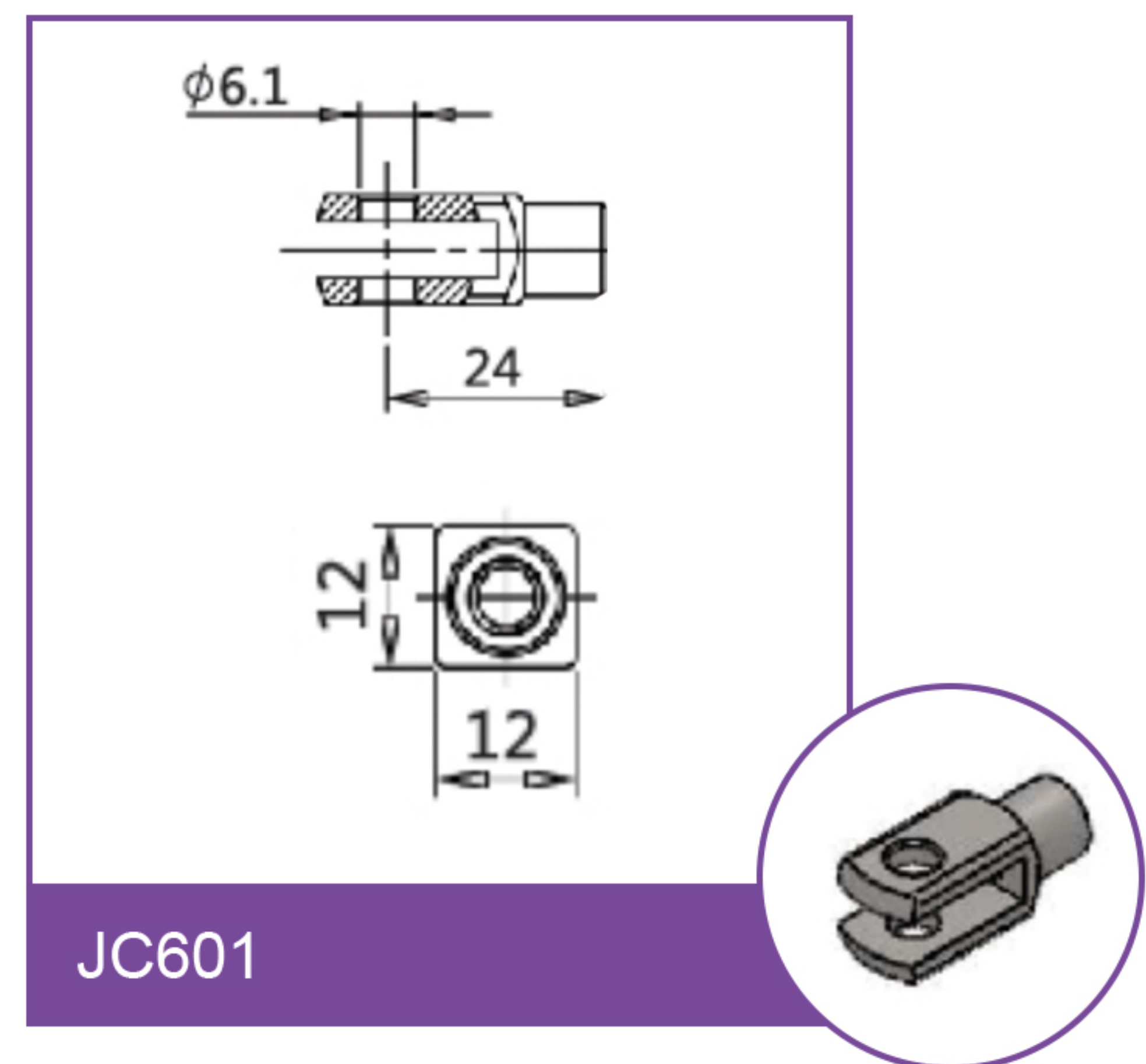

JC601

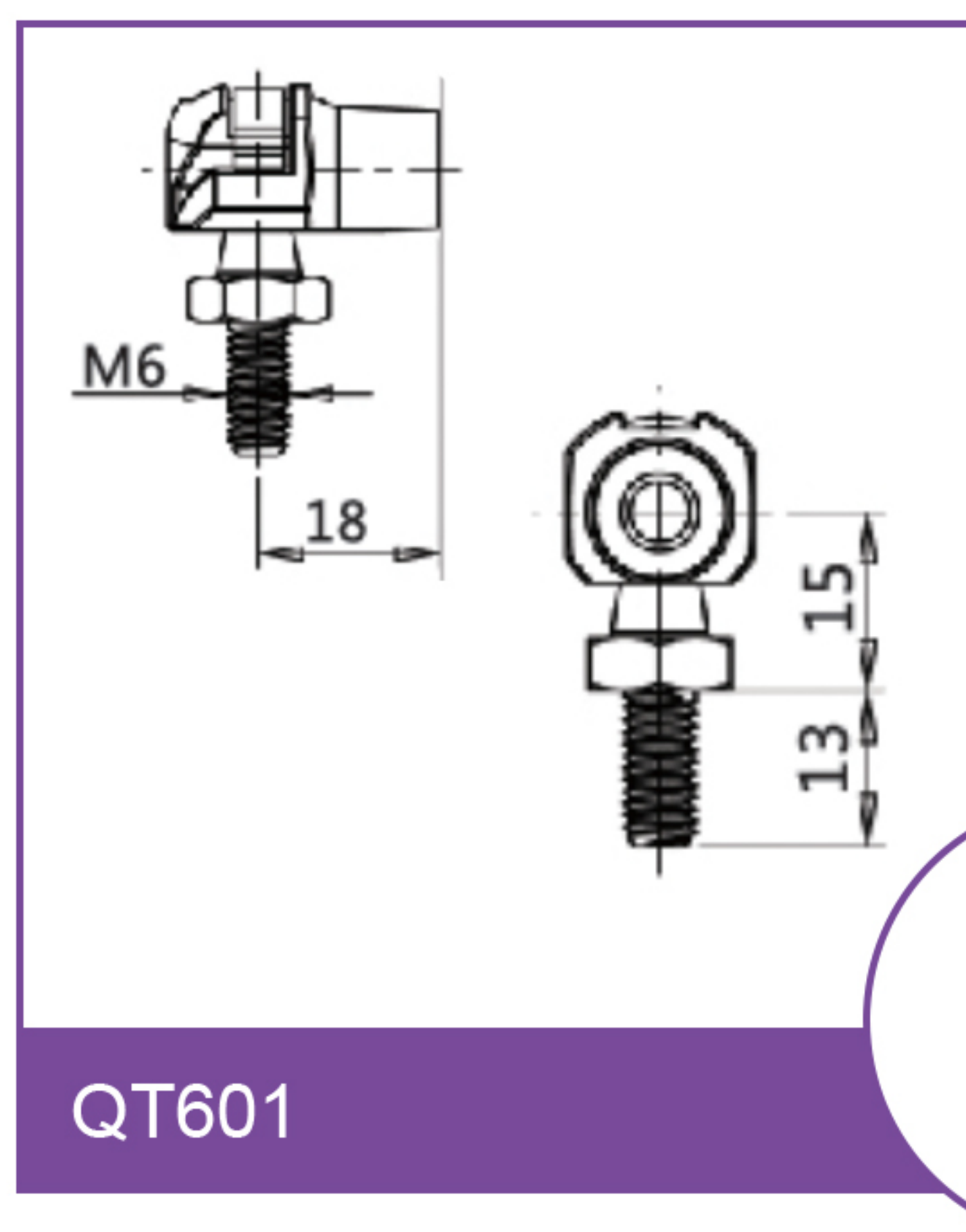

QT601

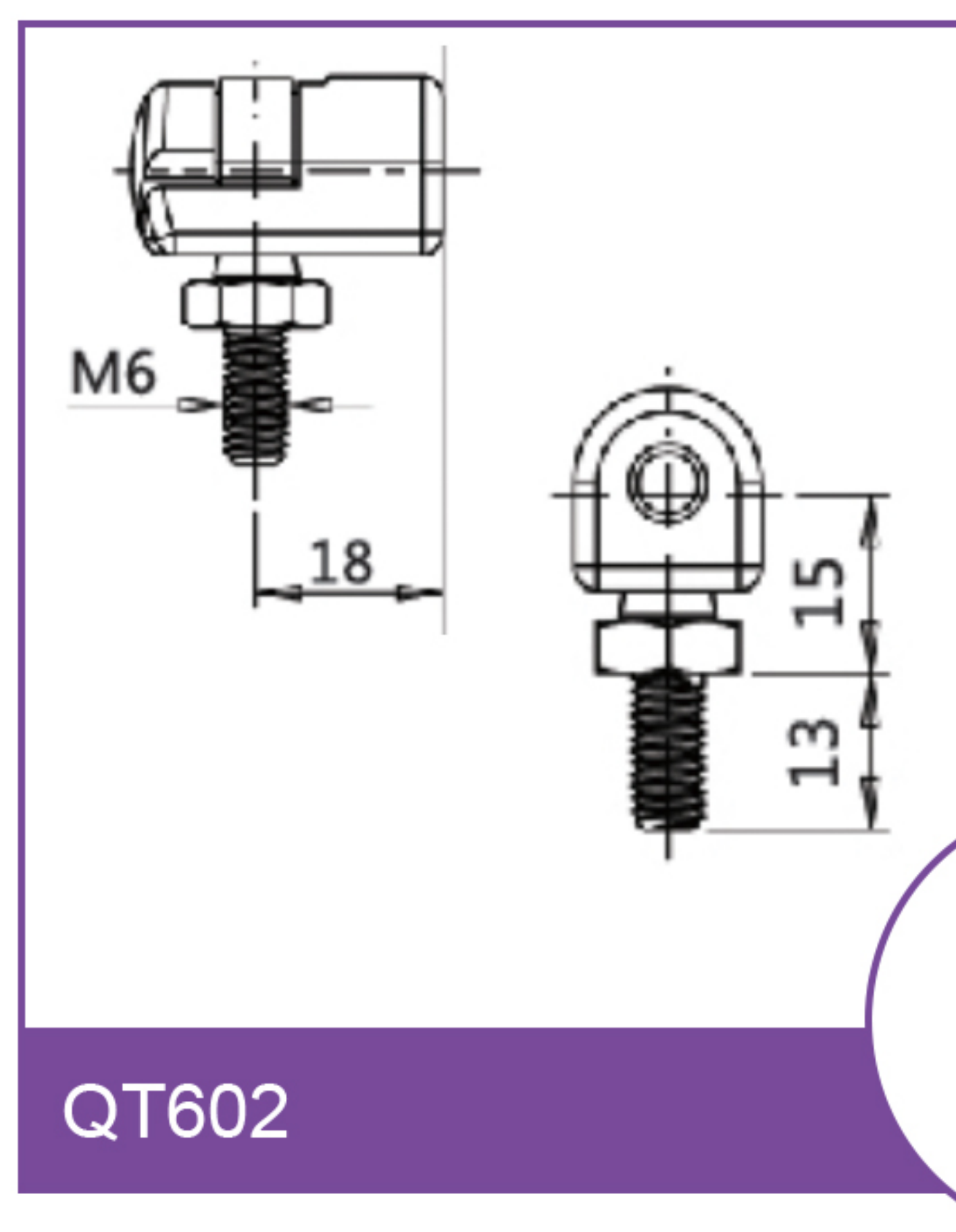

QT602

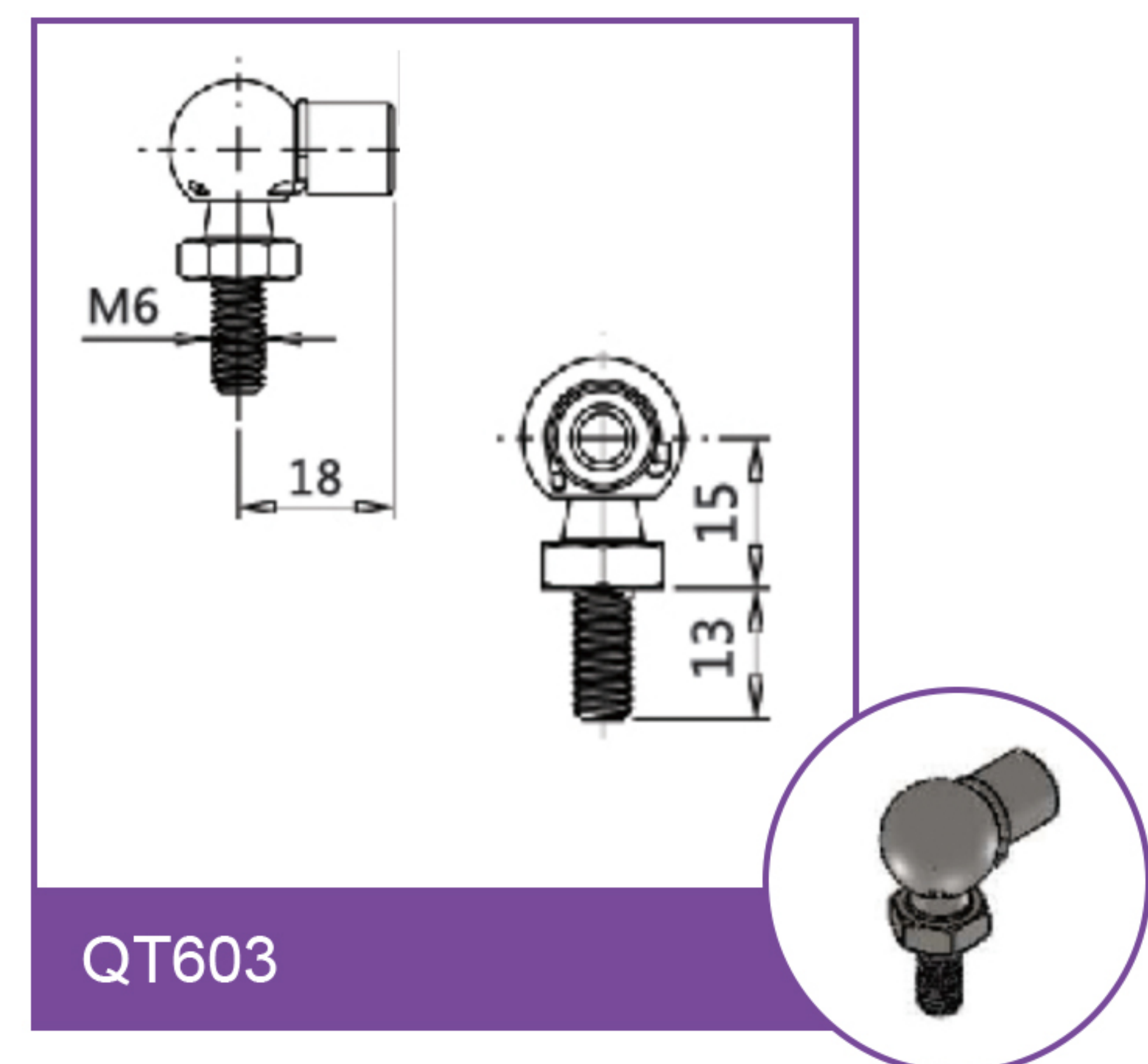

QT603

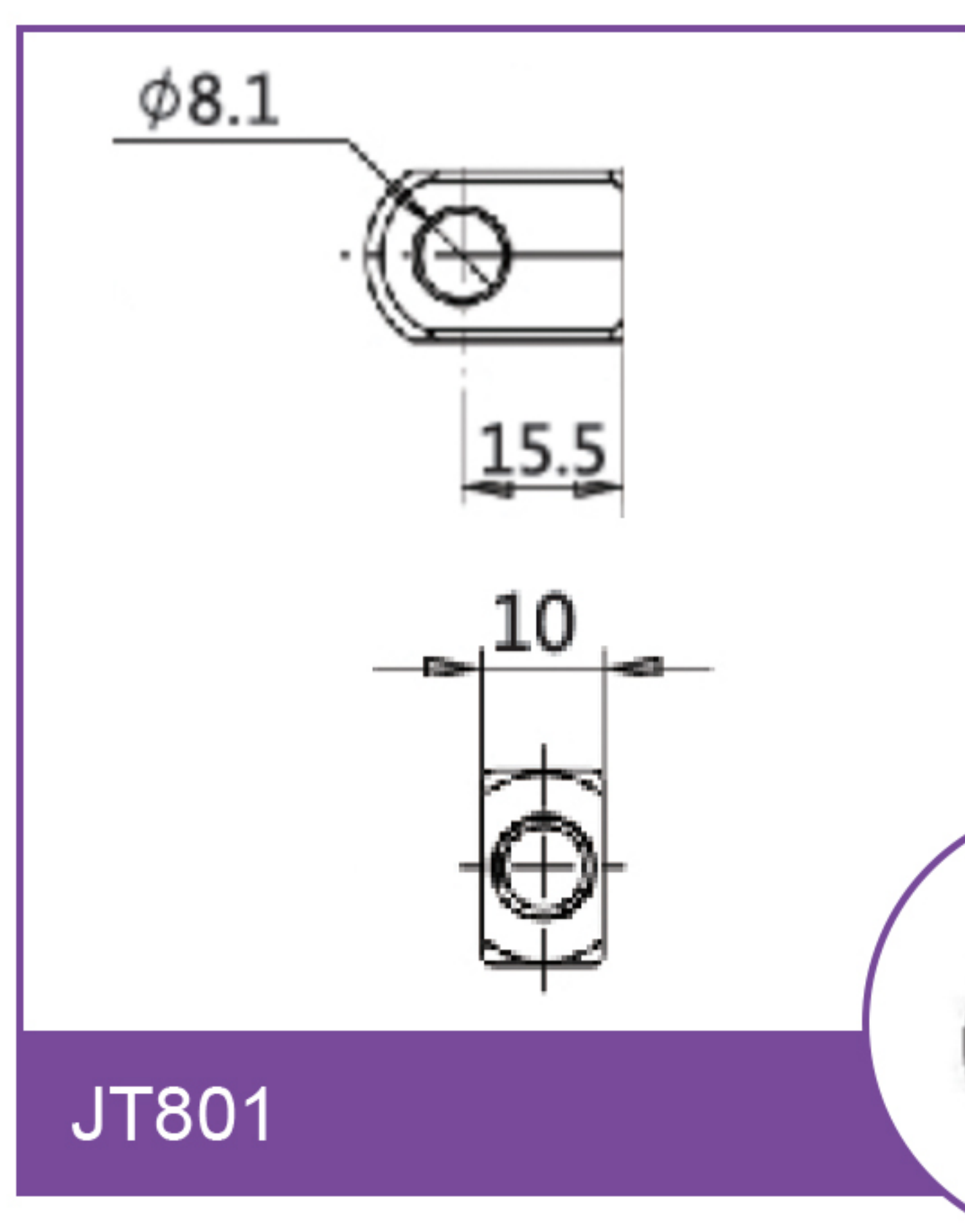

JT801

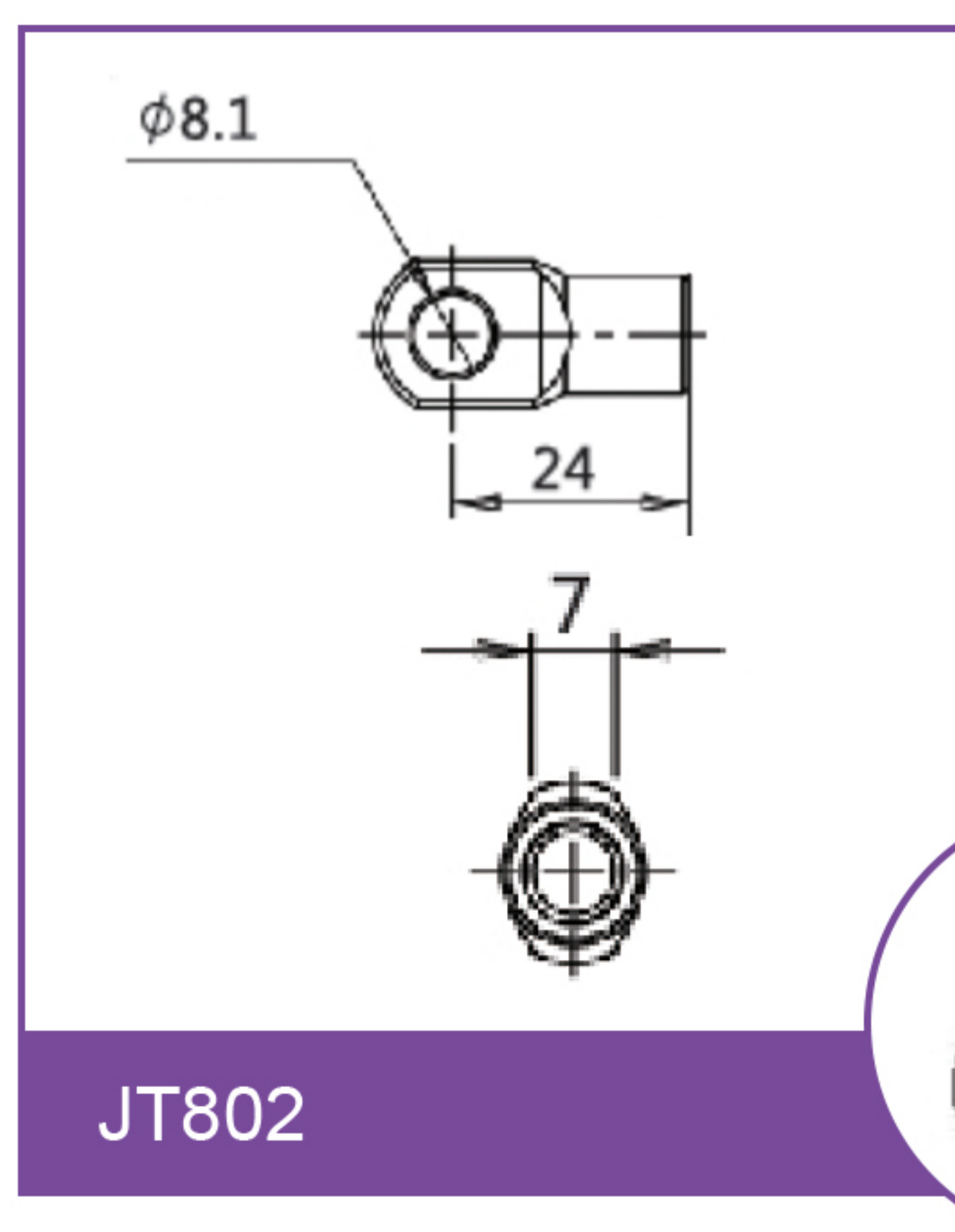

JT802

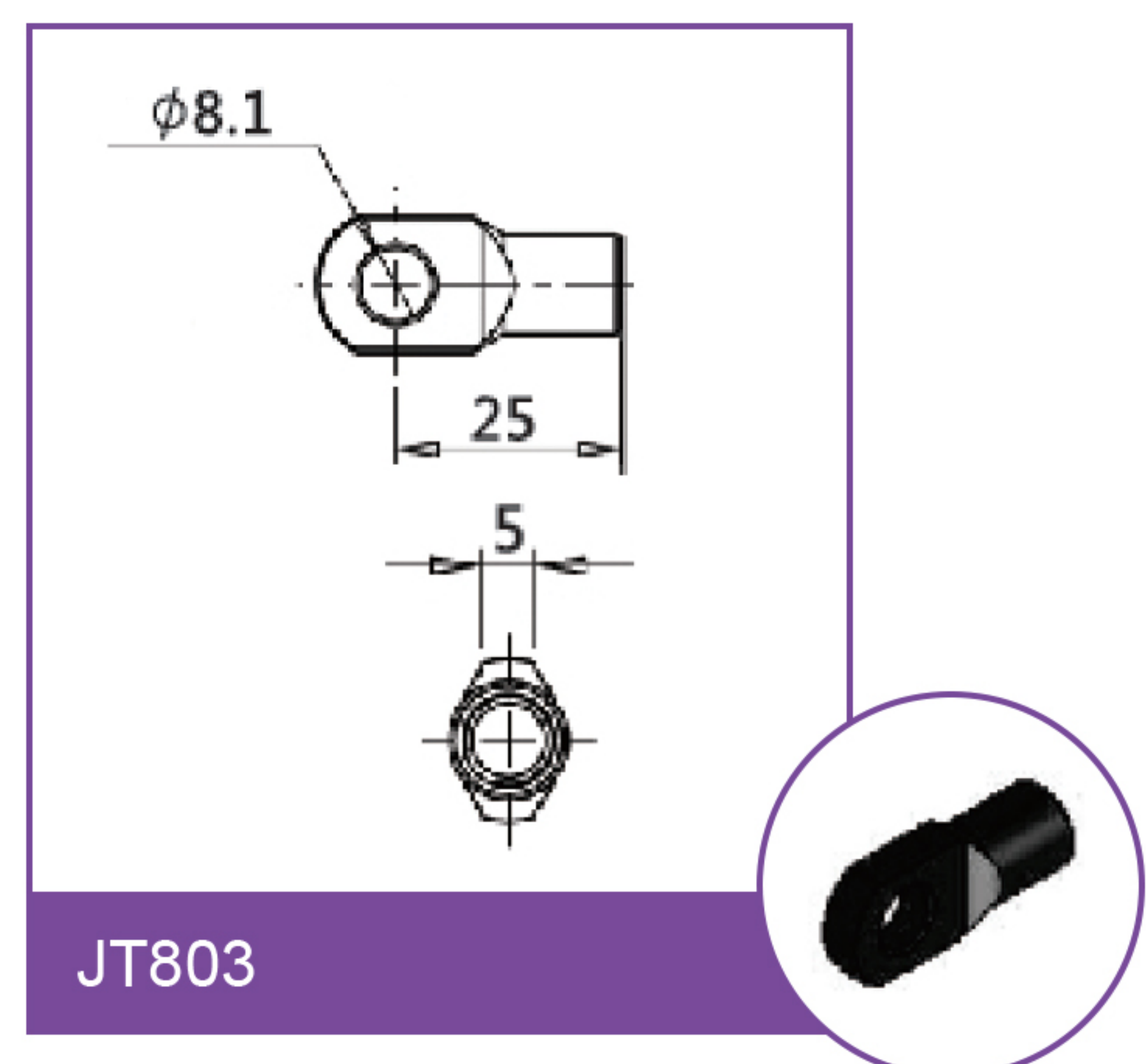

JT803



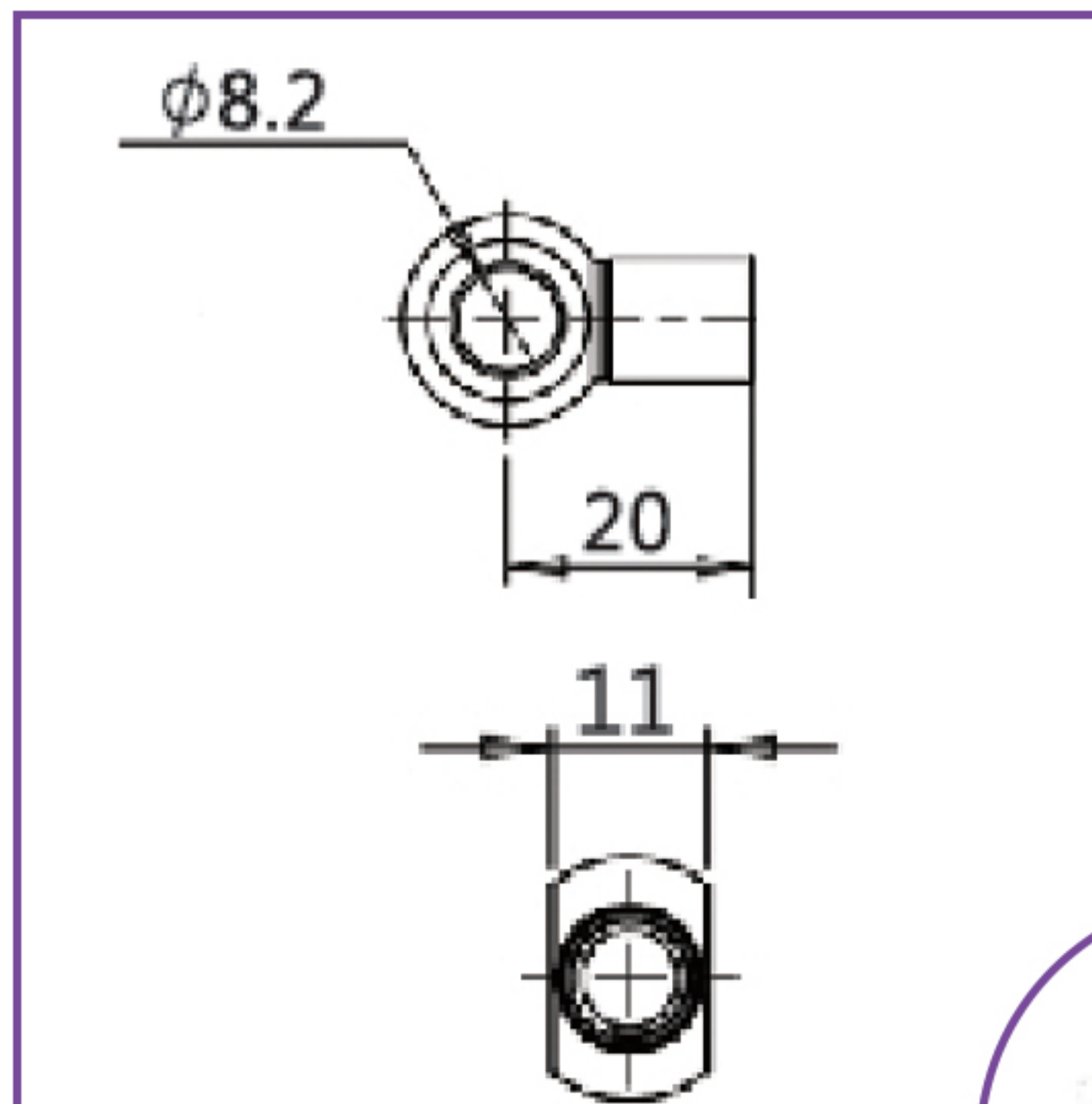

JT804

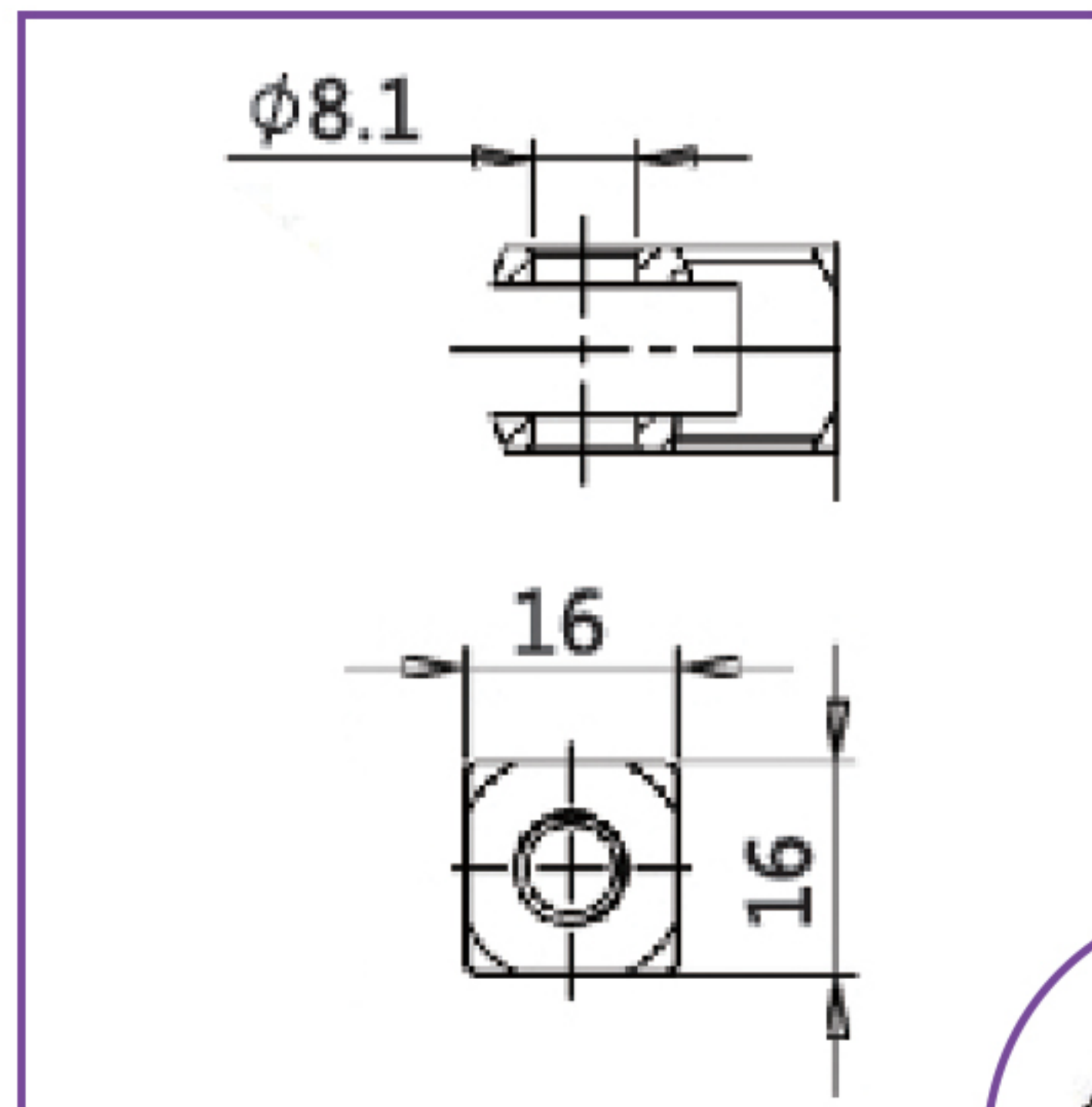
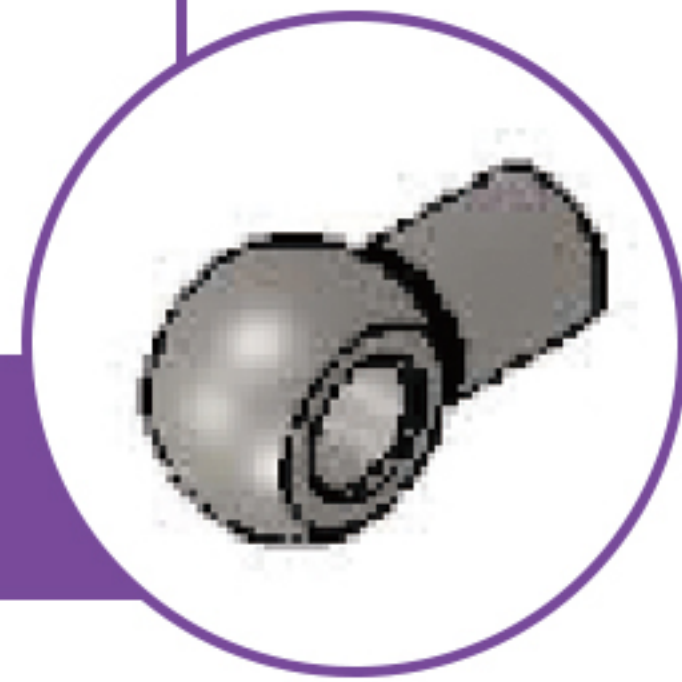

JC801

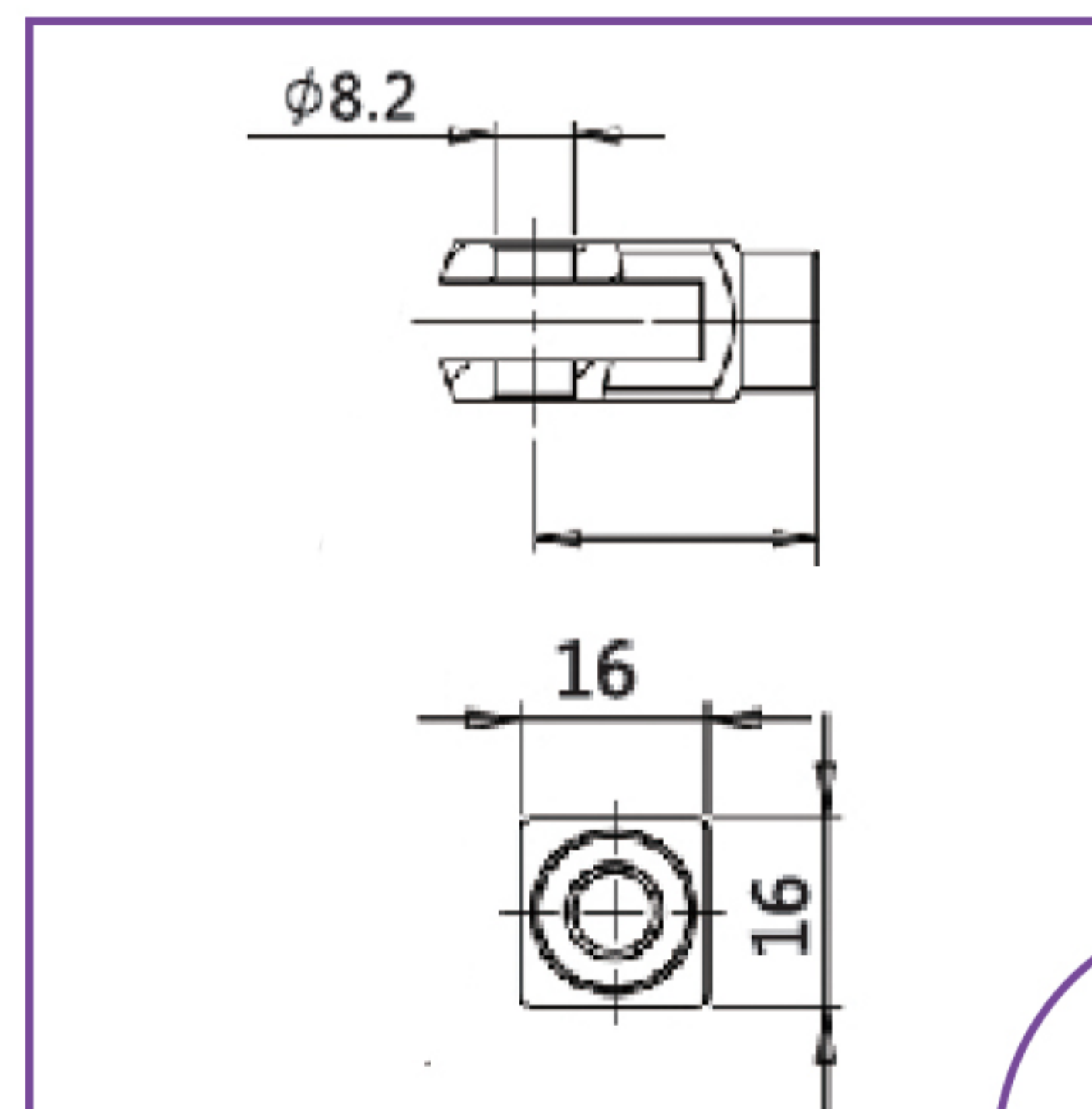
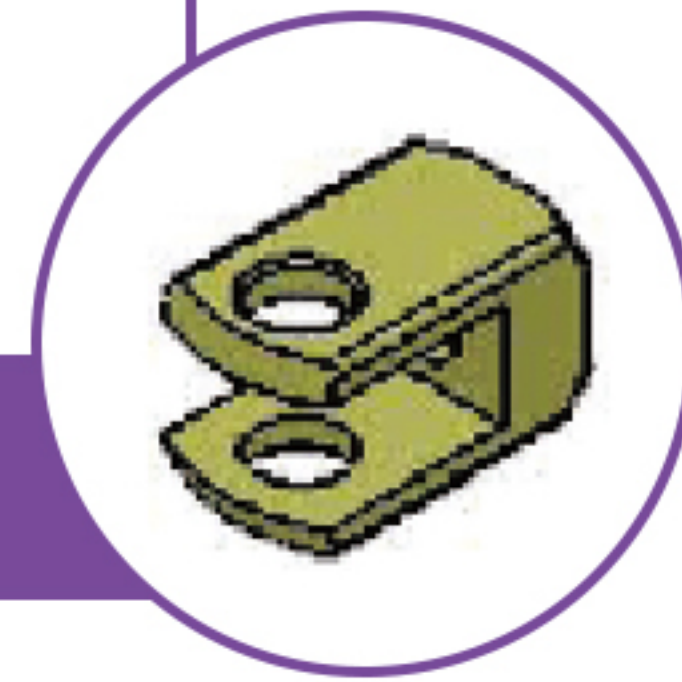

JC802

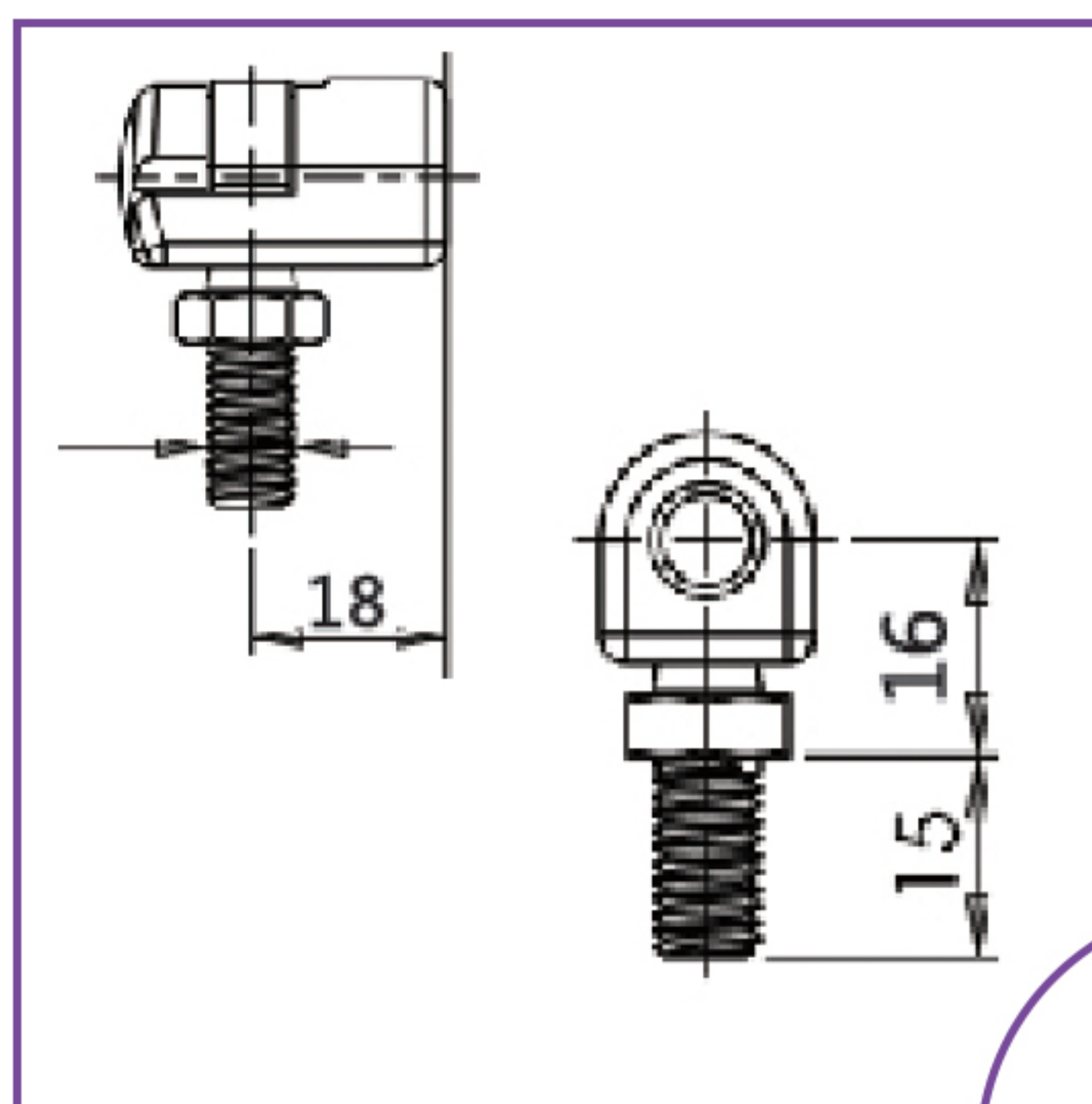
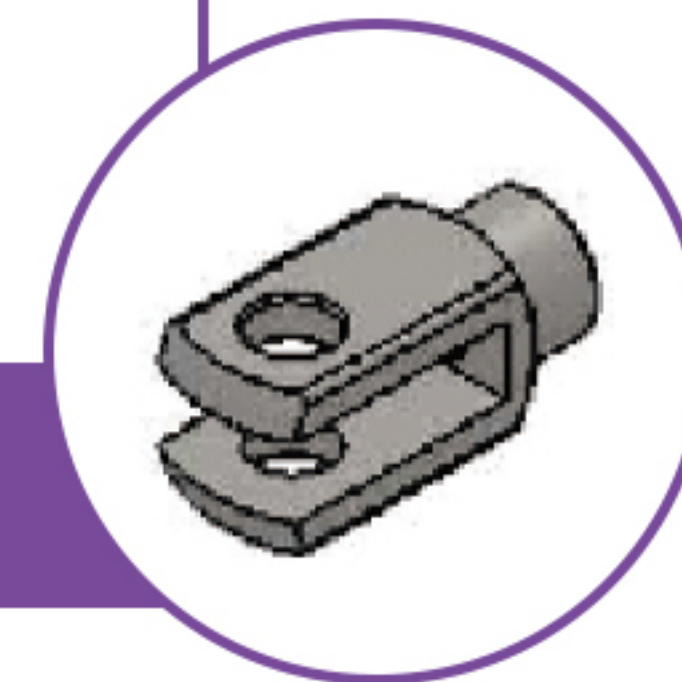

QT801

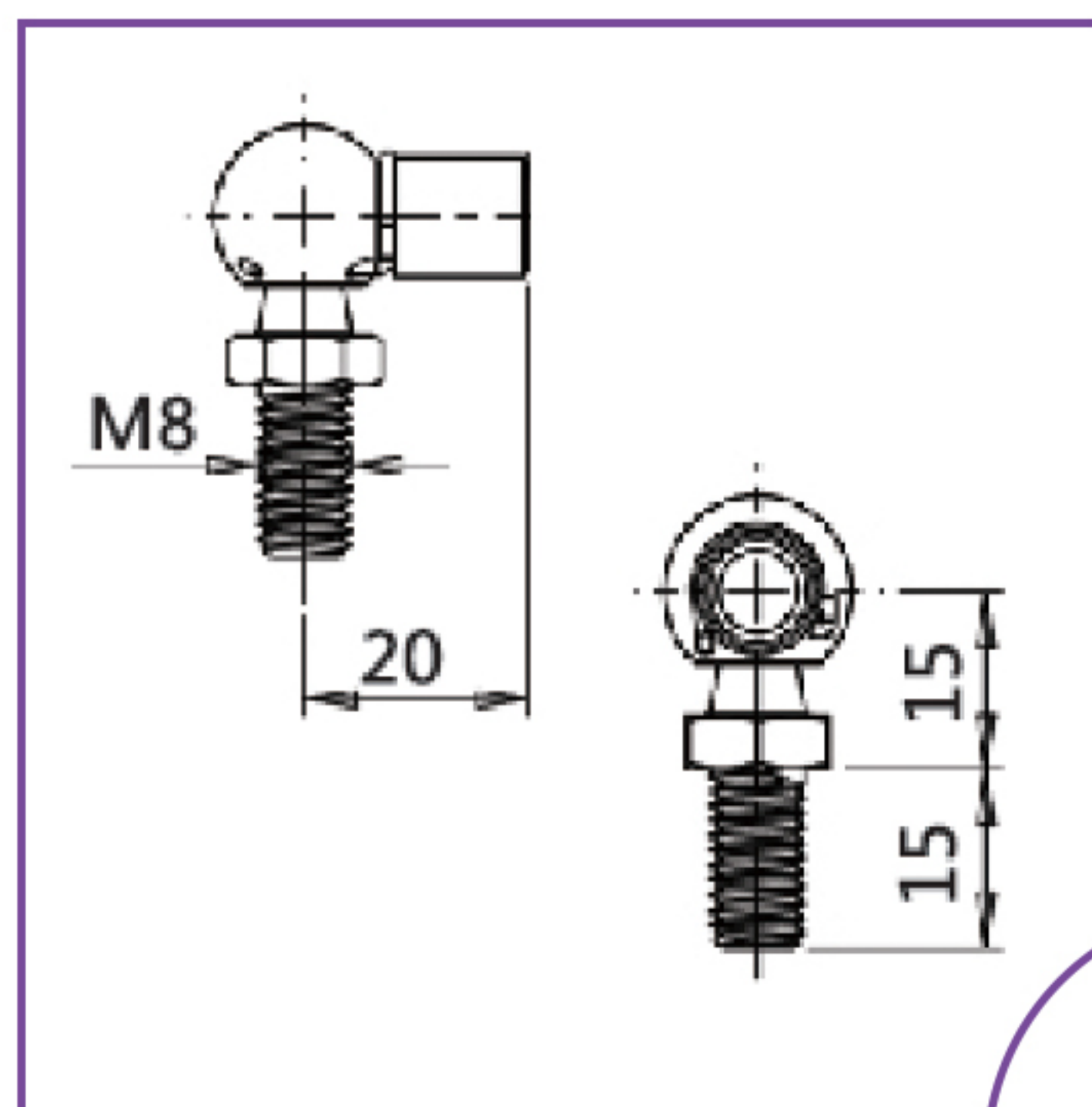

QT802

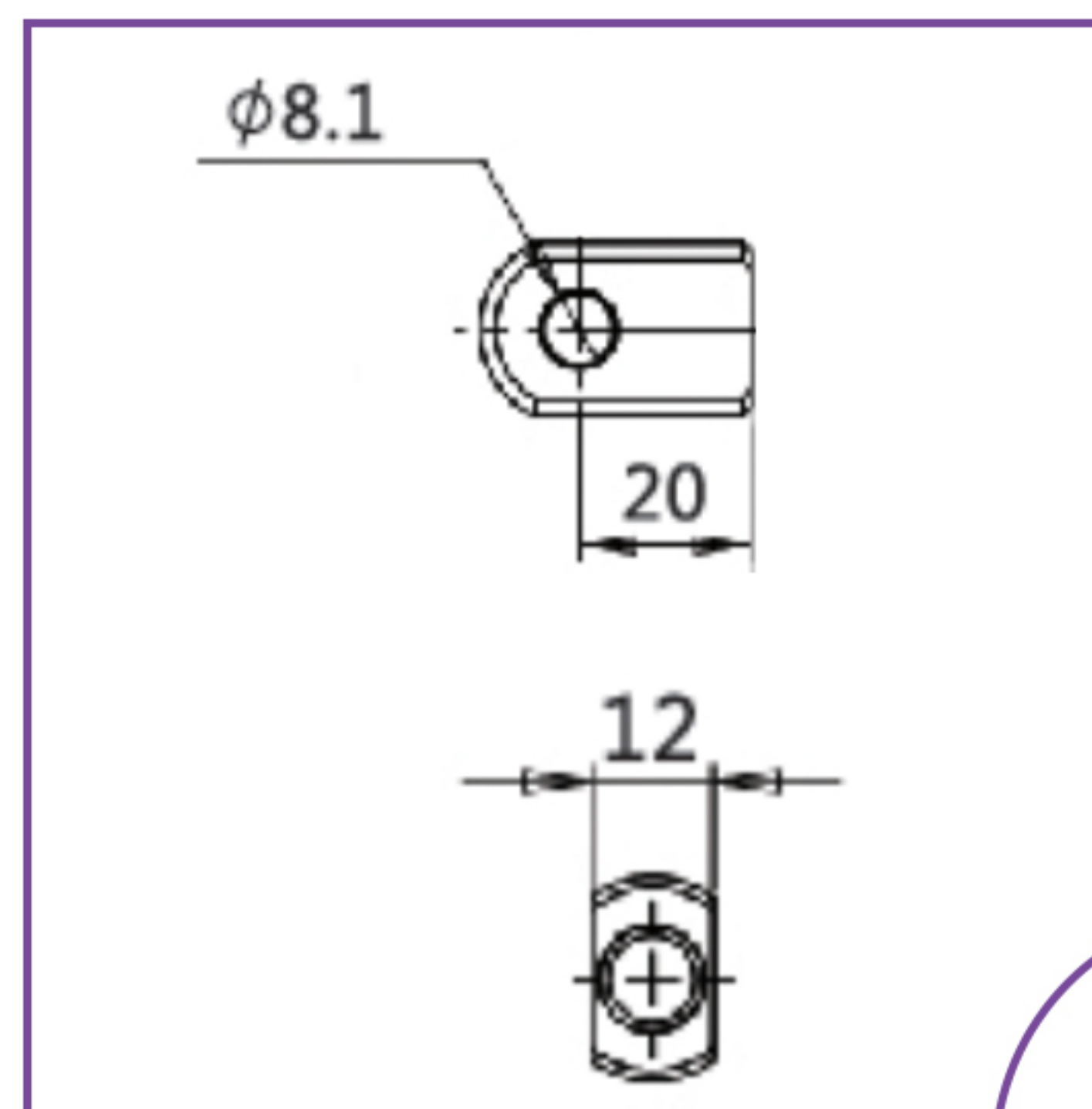

JT1201

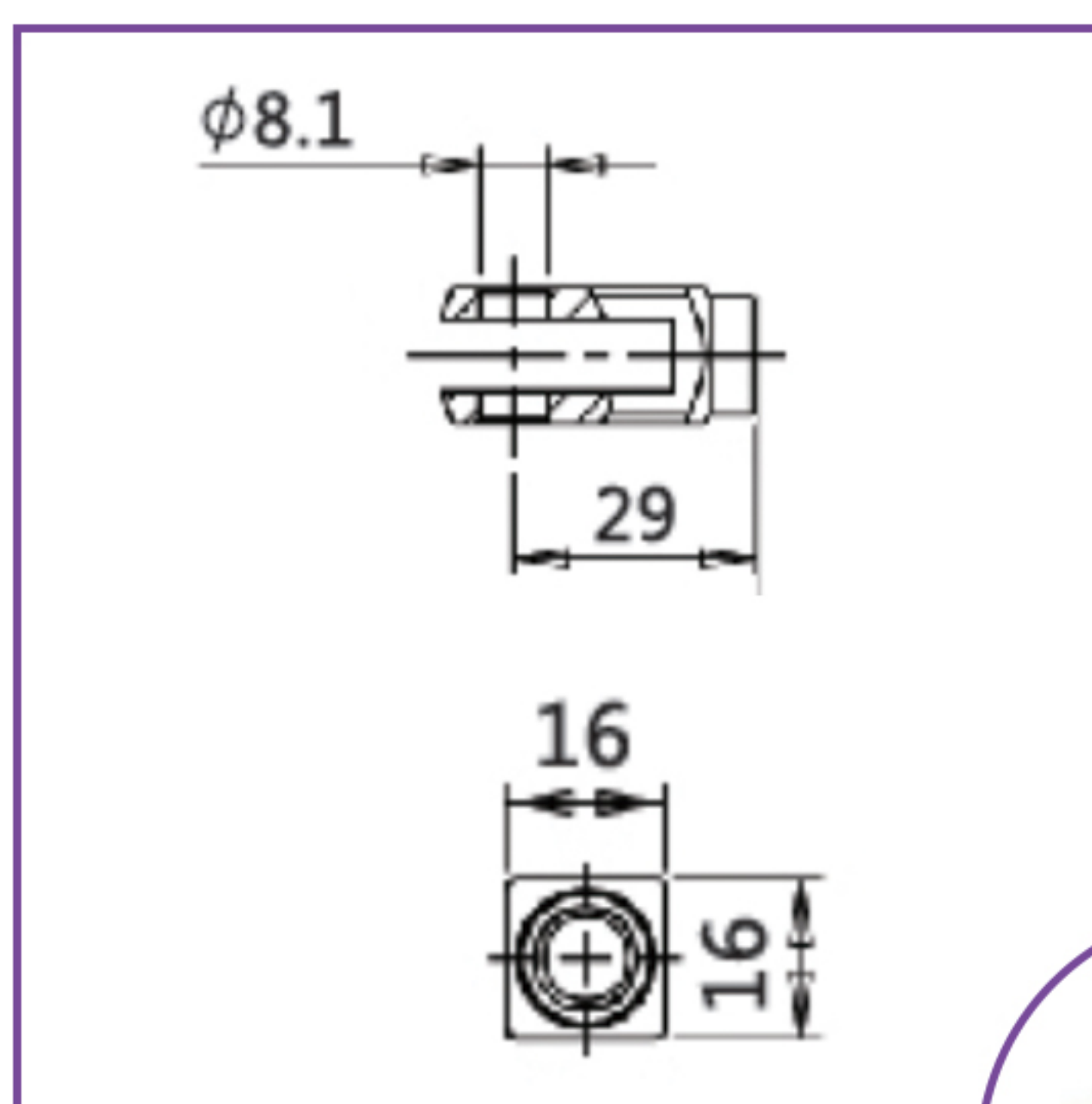

JC1201

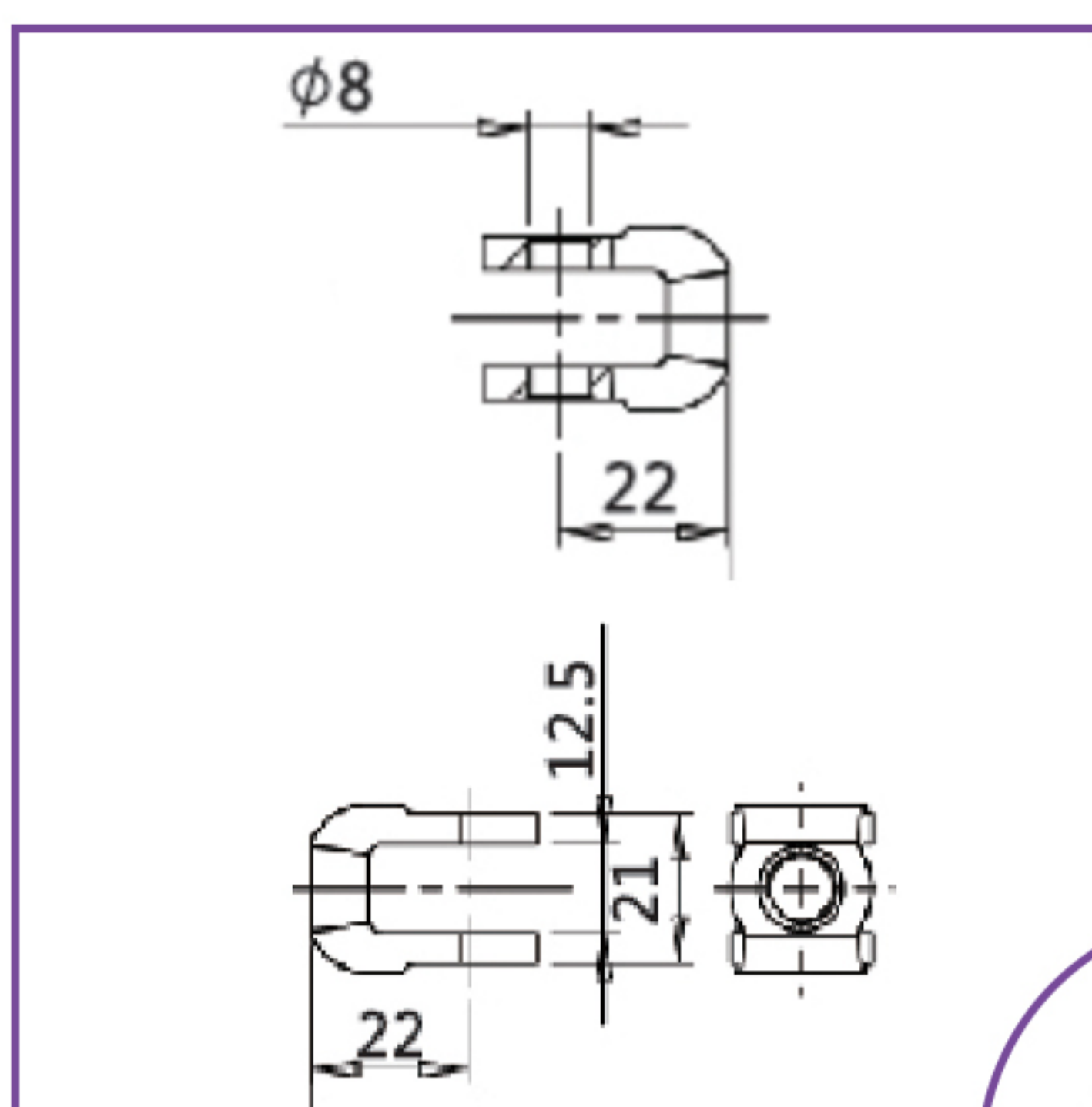

JC1202

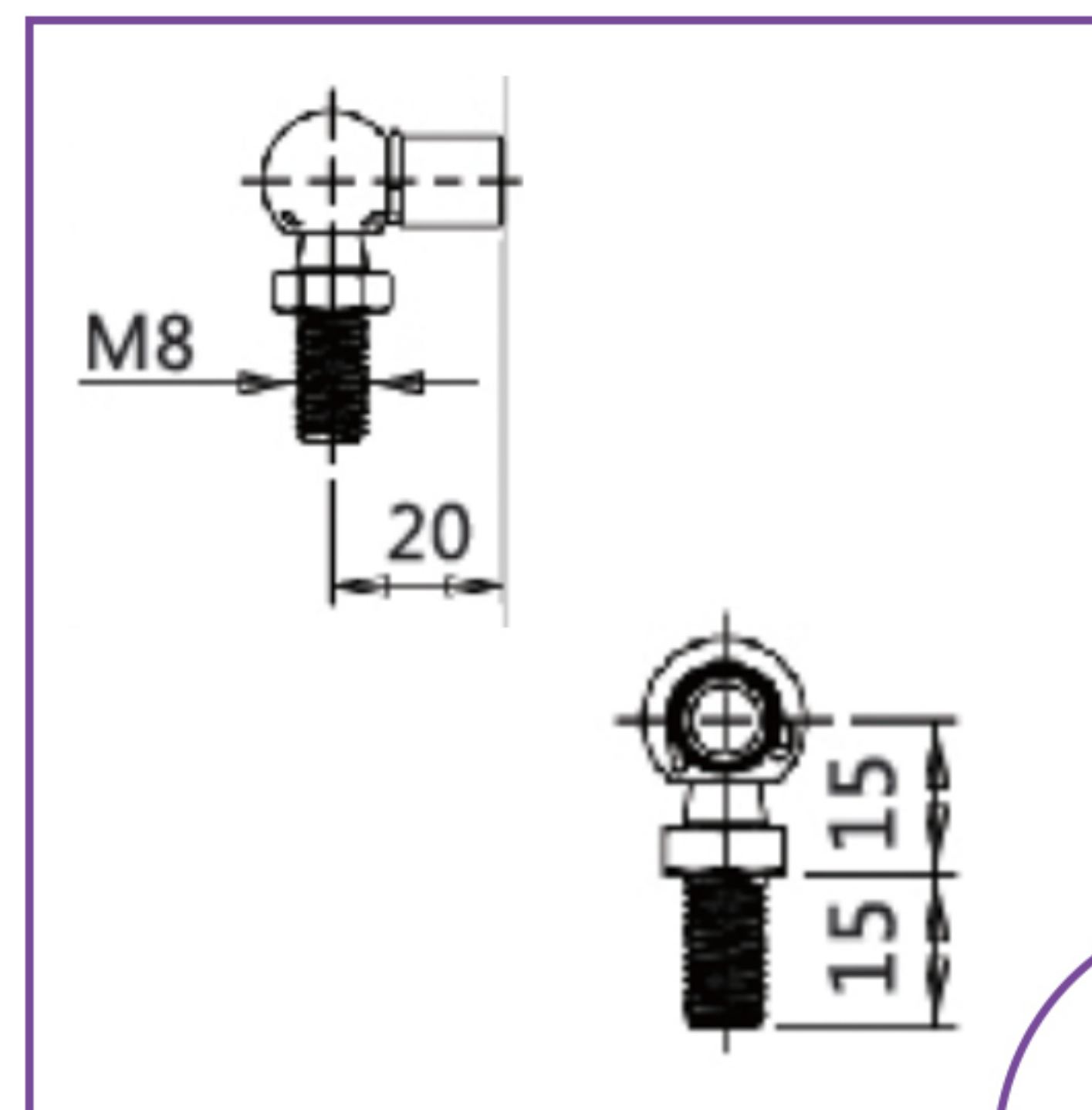
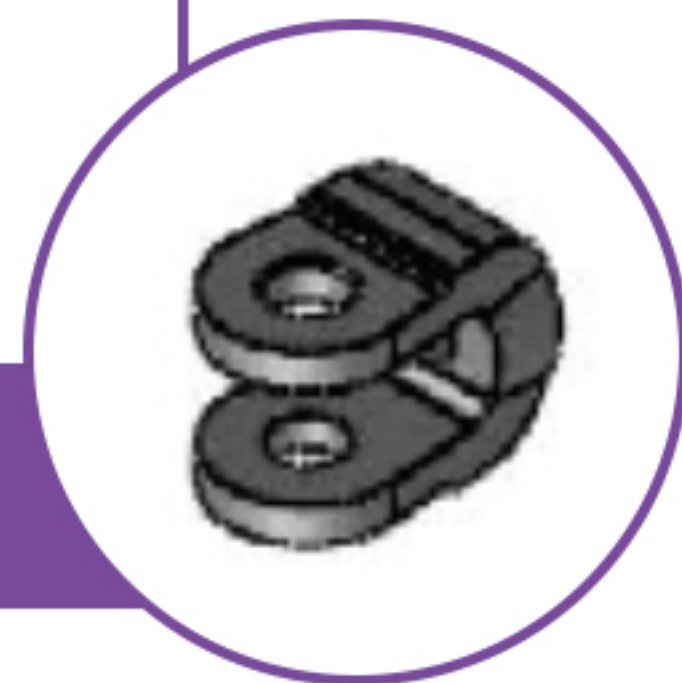

QT1201





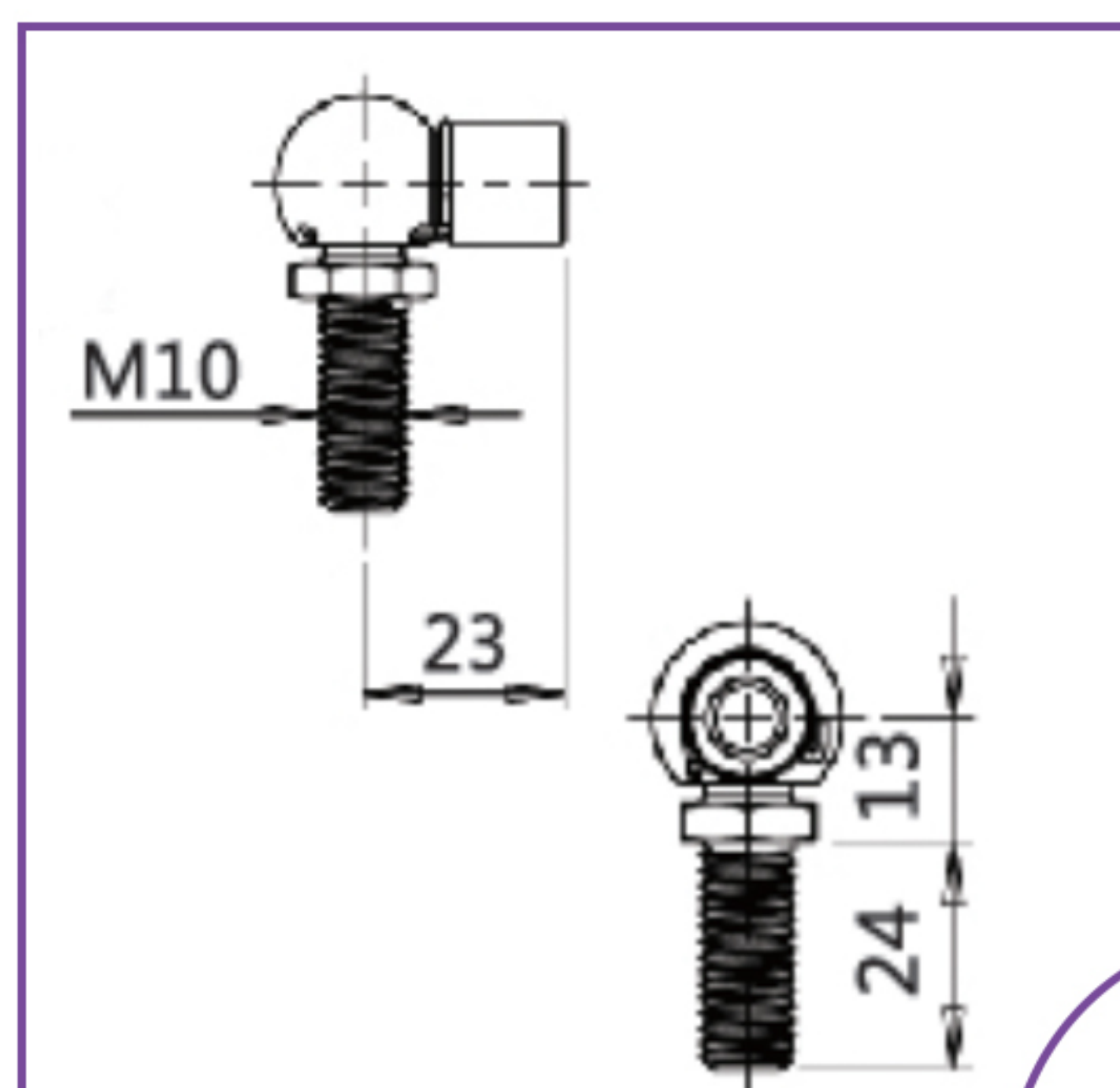

QT1202

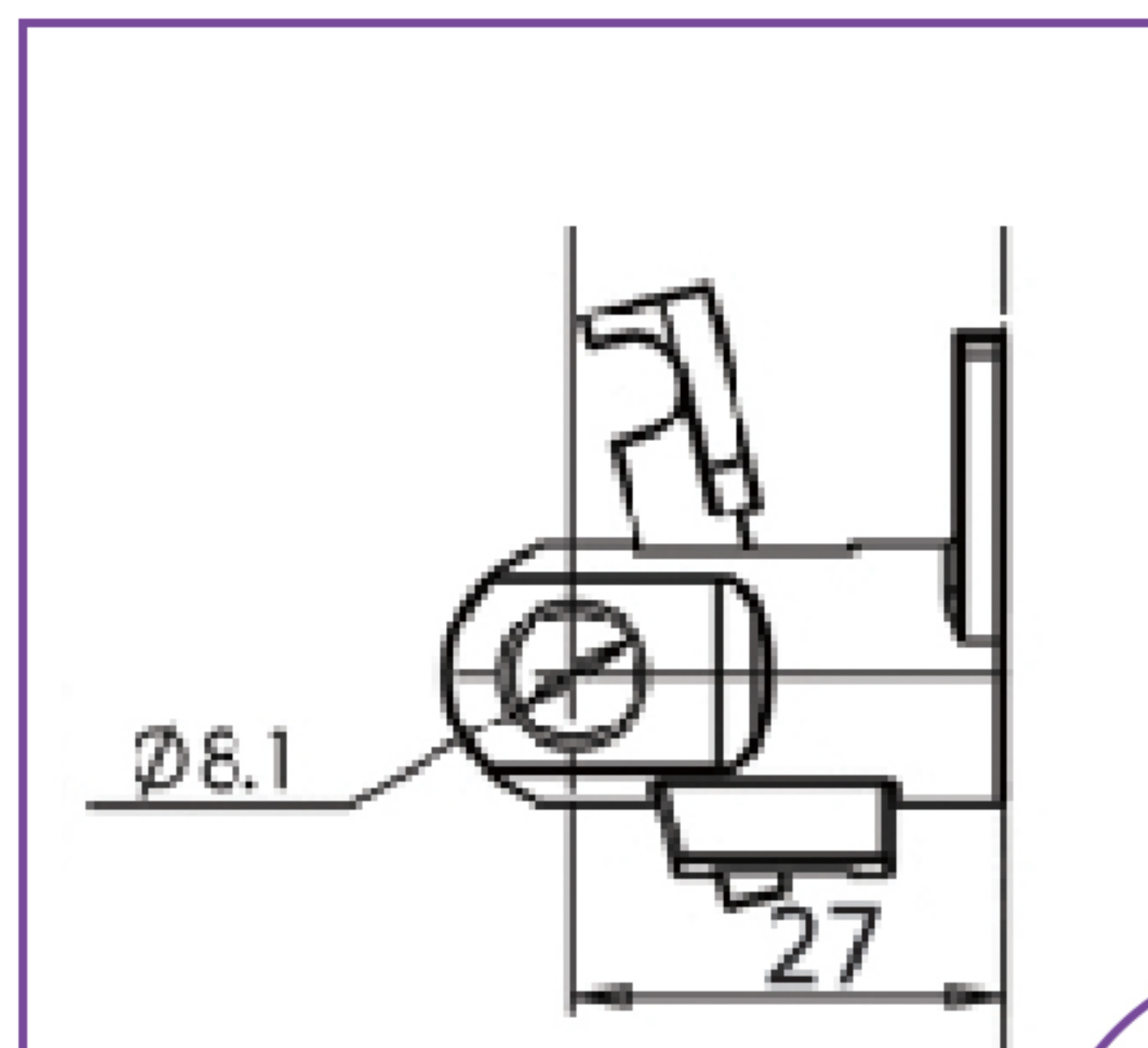

YT01

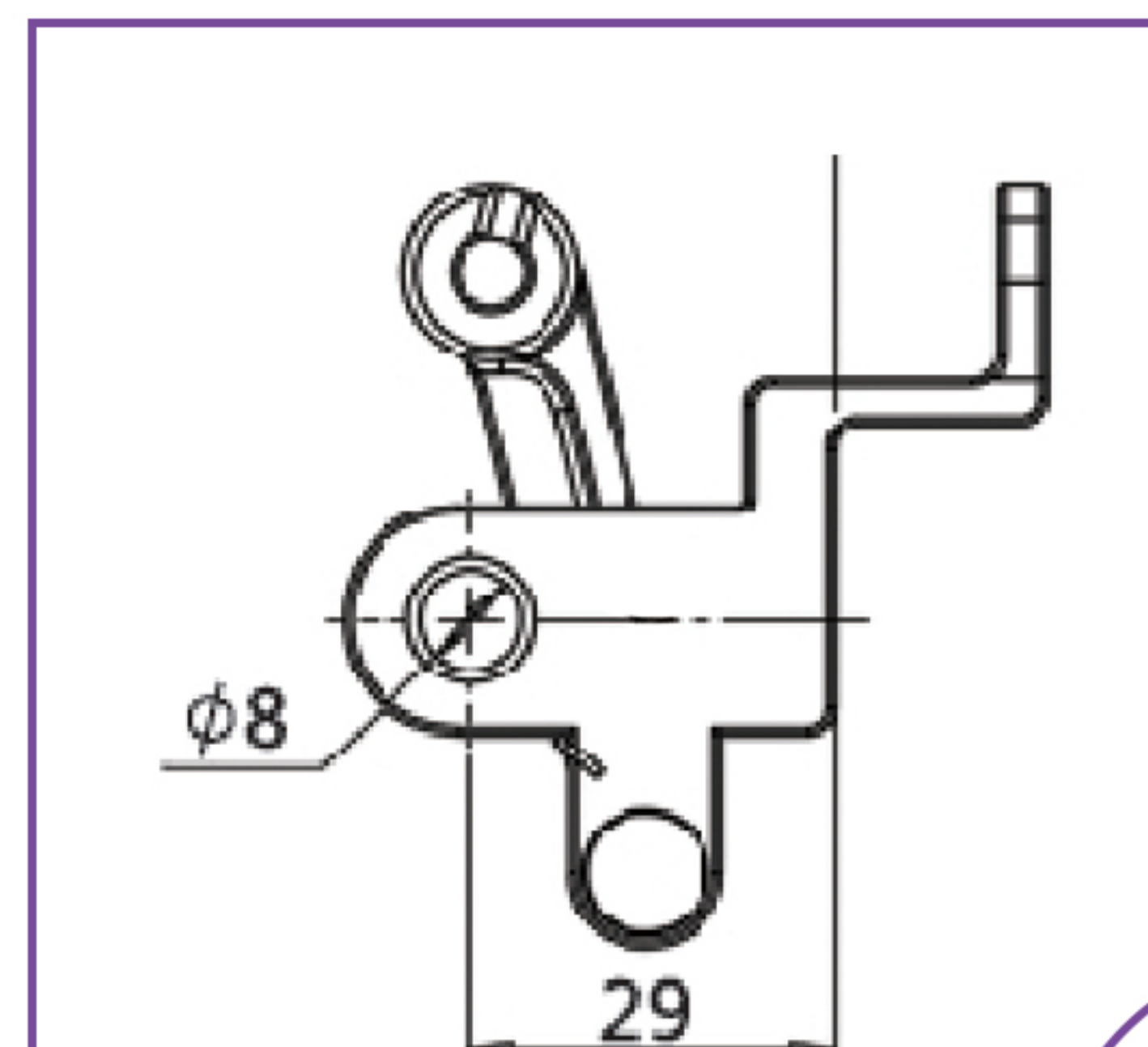

YT02

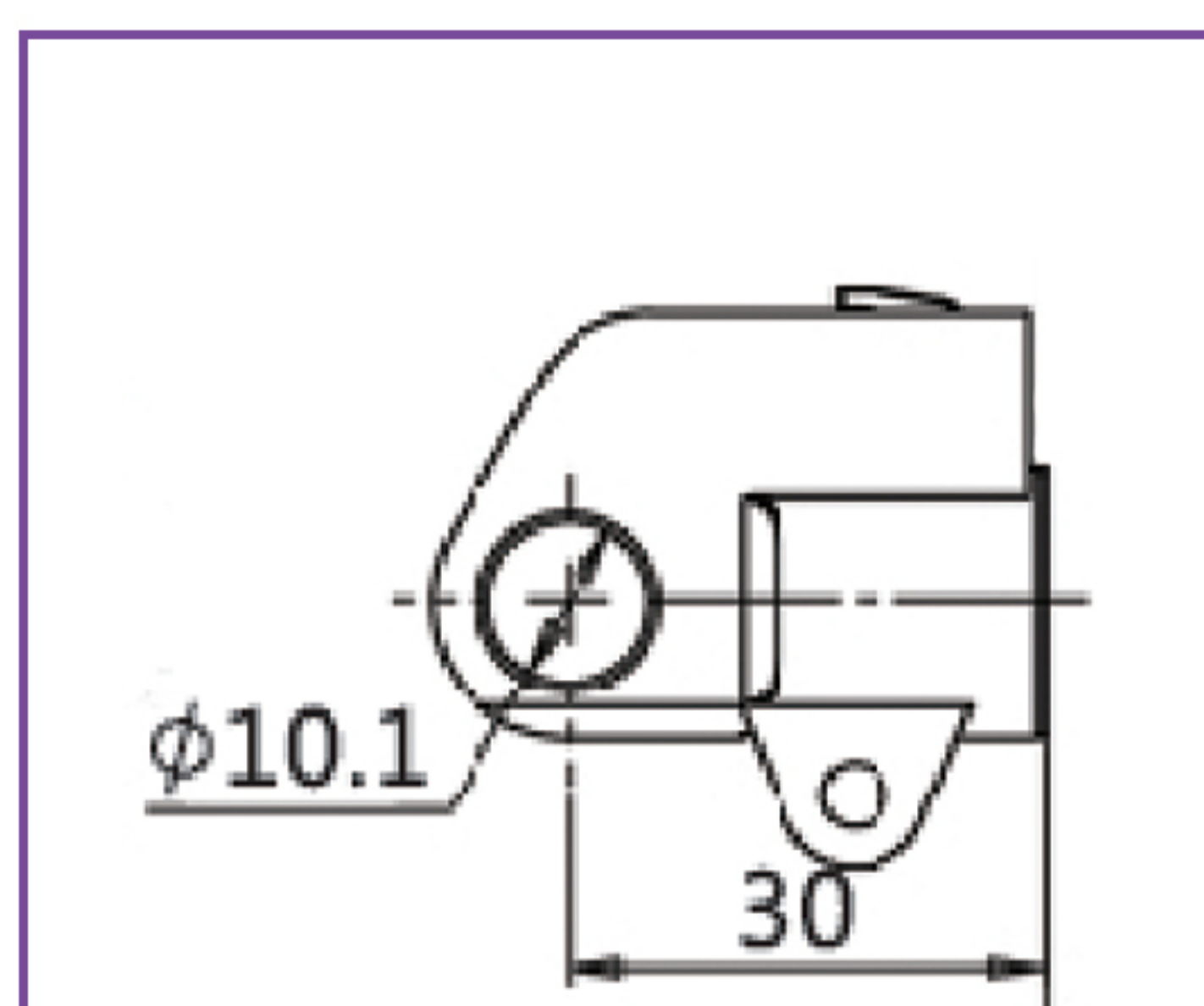
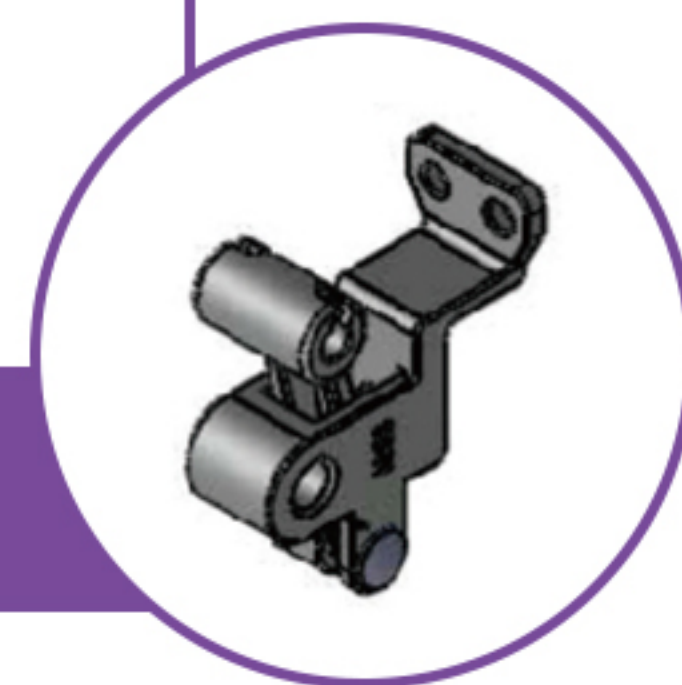

YT04

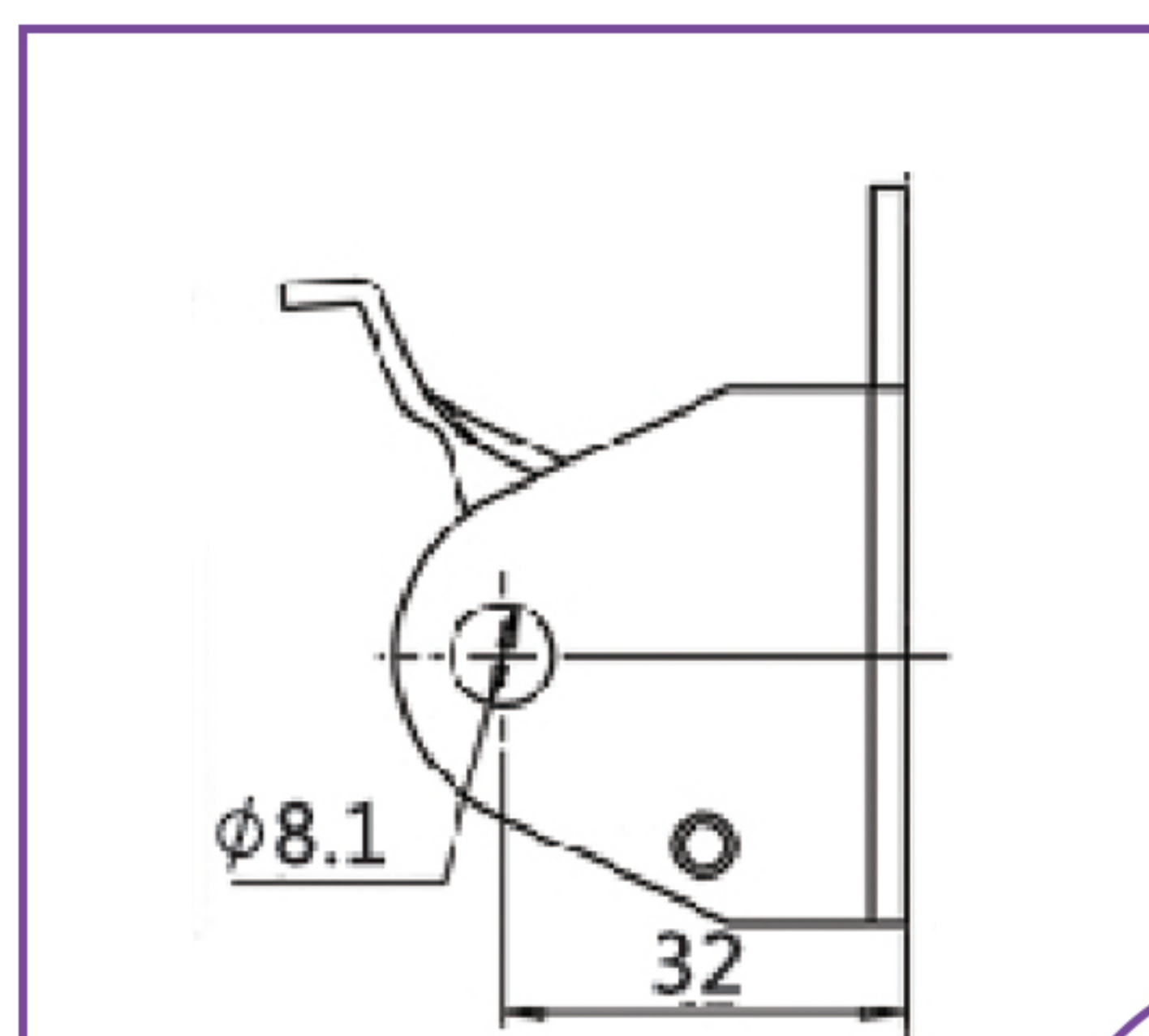

YT05

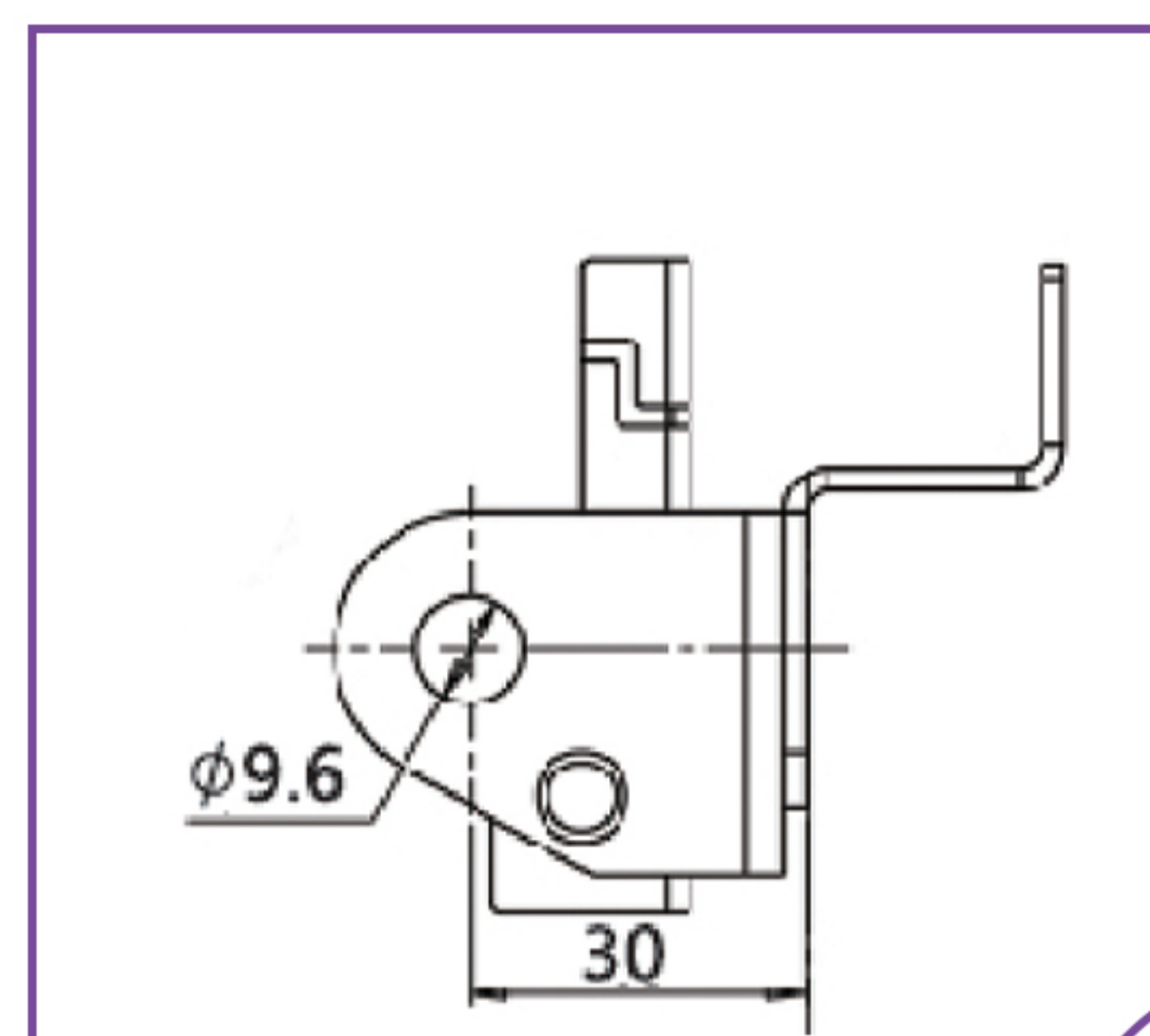

YT06

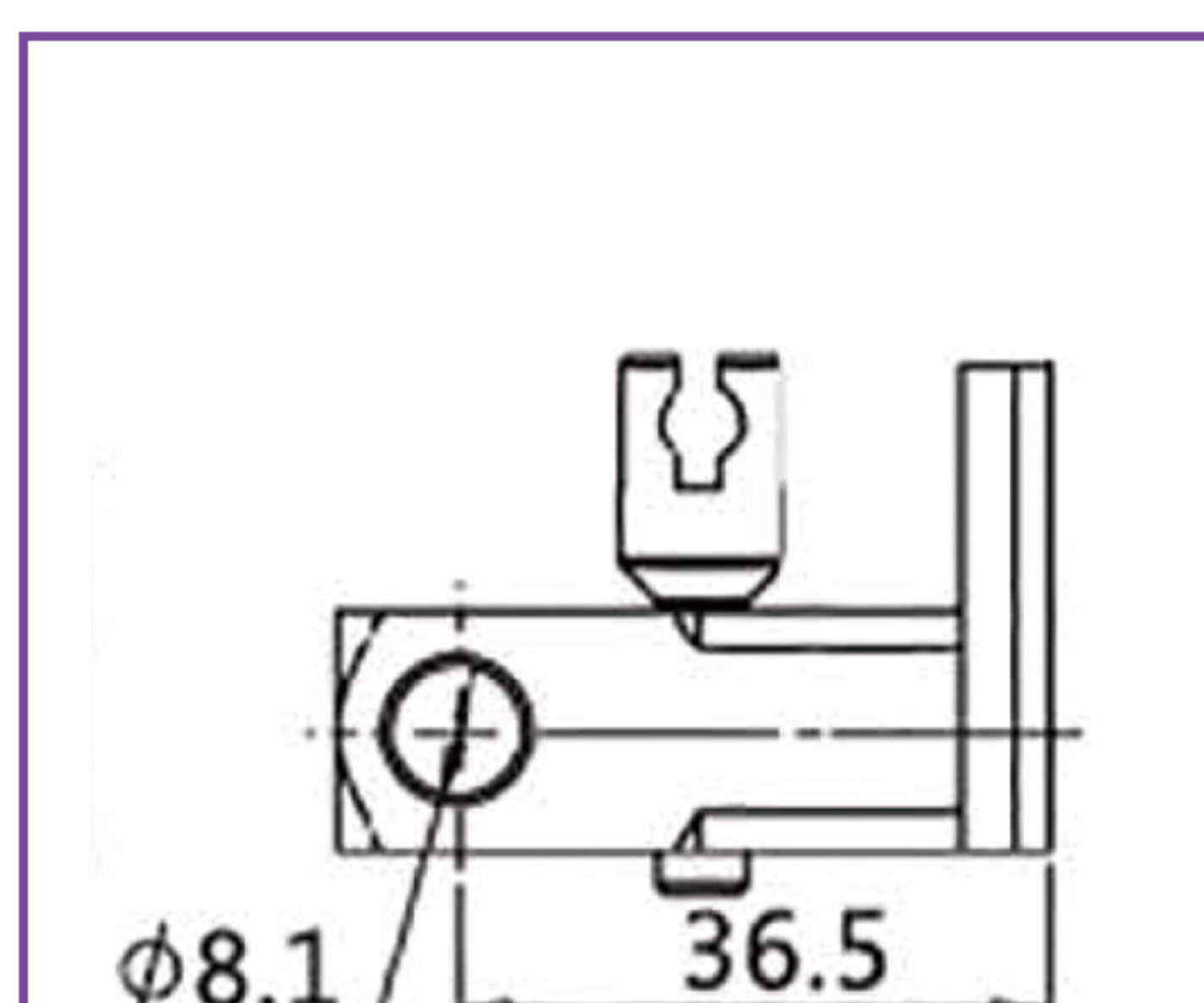
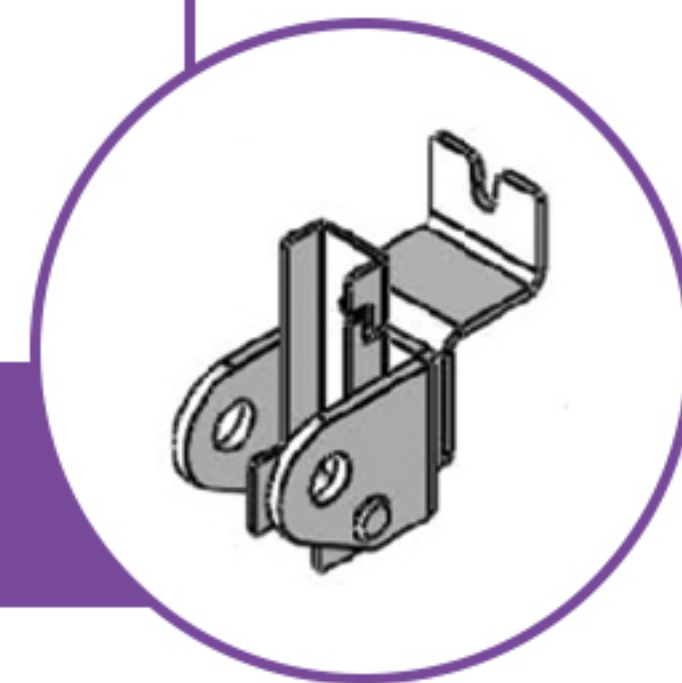

YT07

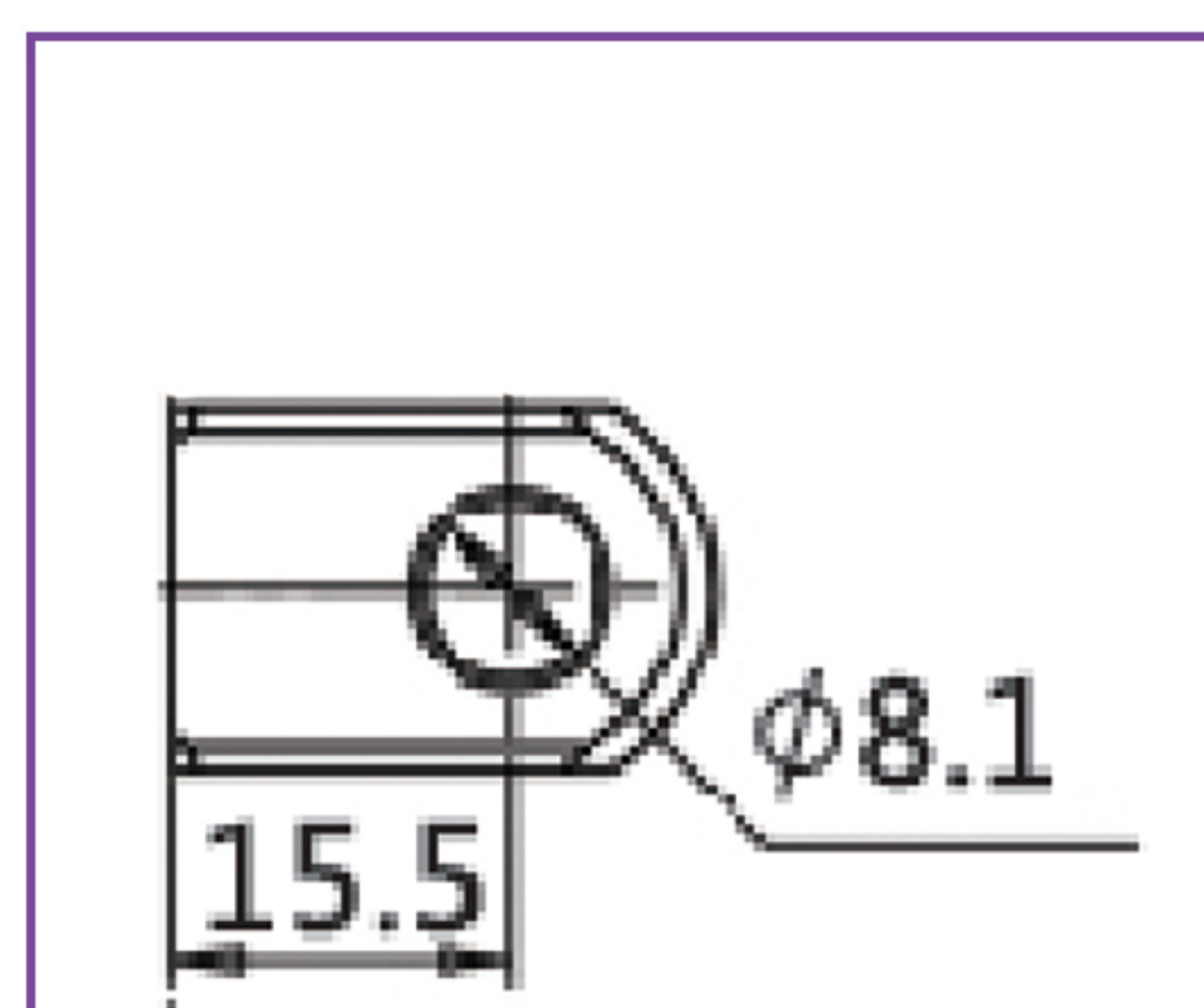
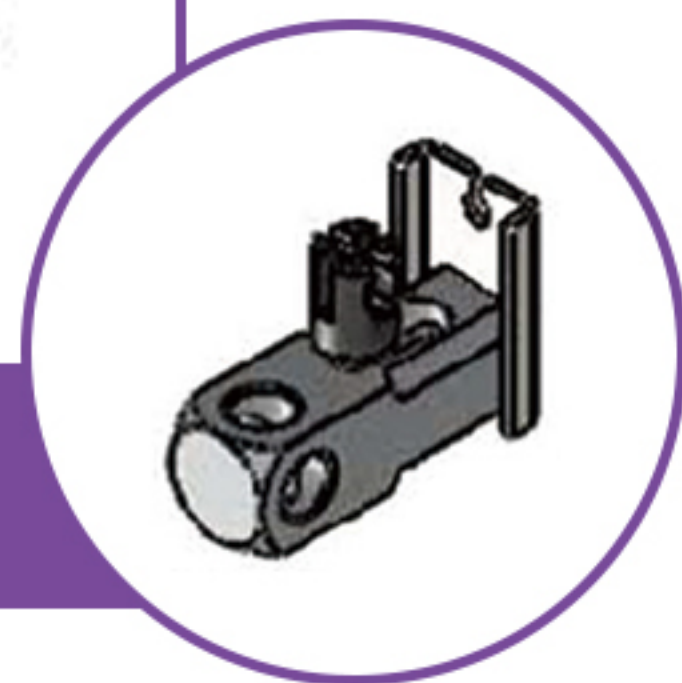

KJT01

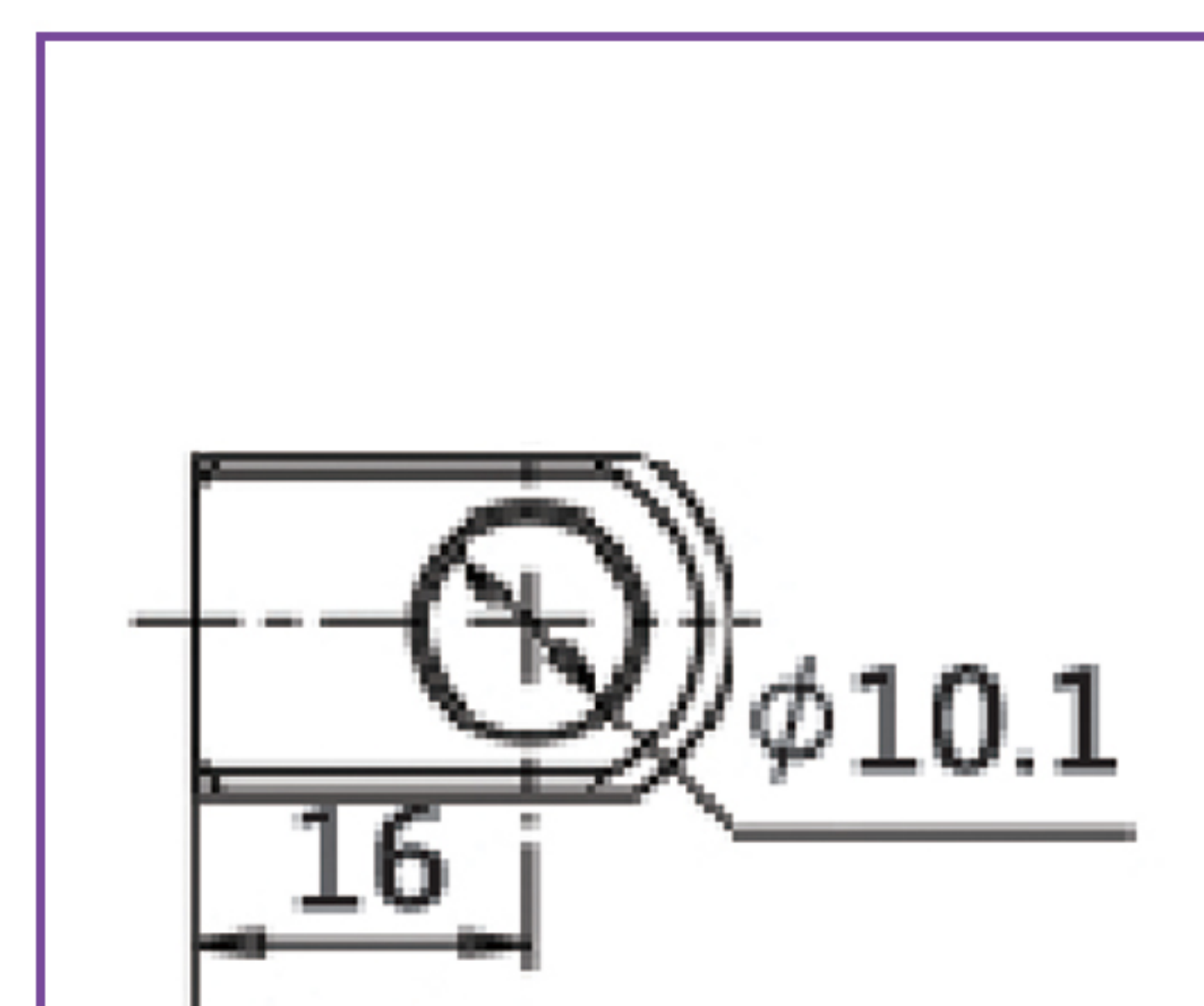
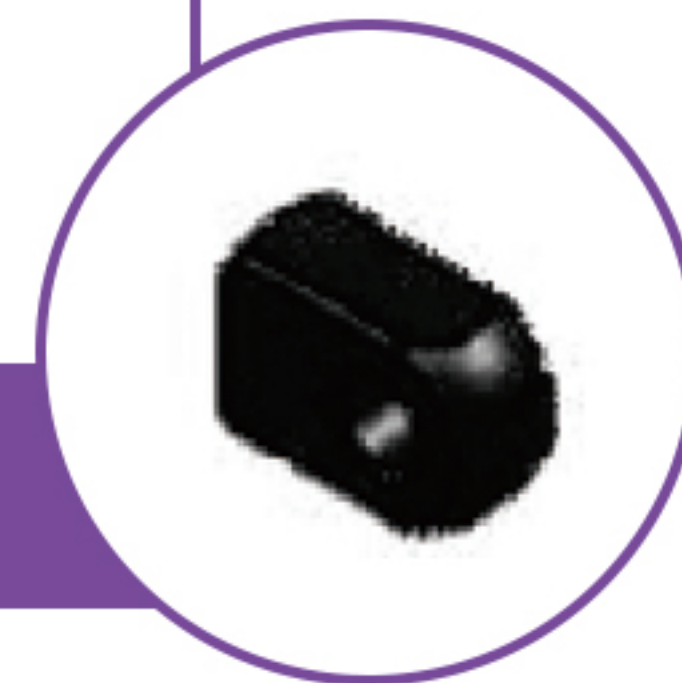

KJT02

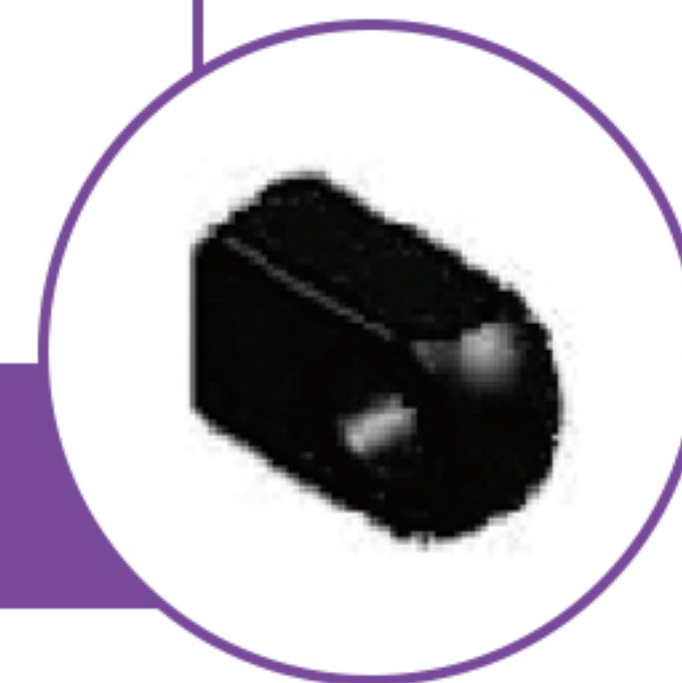



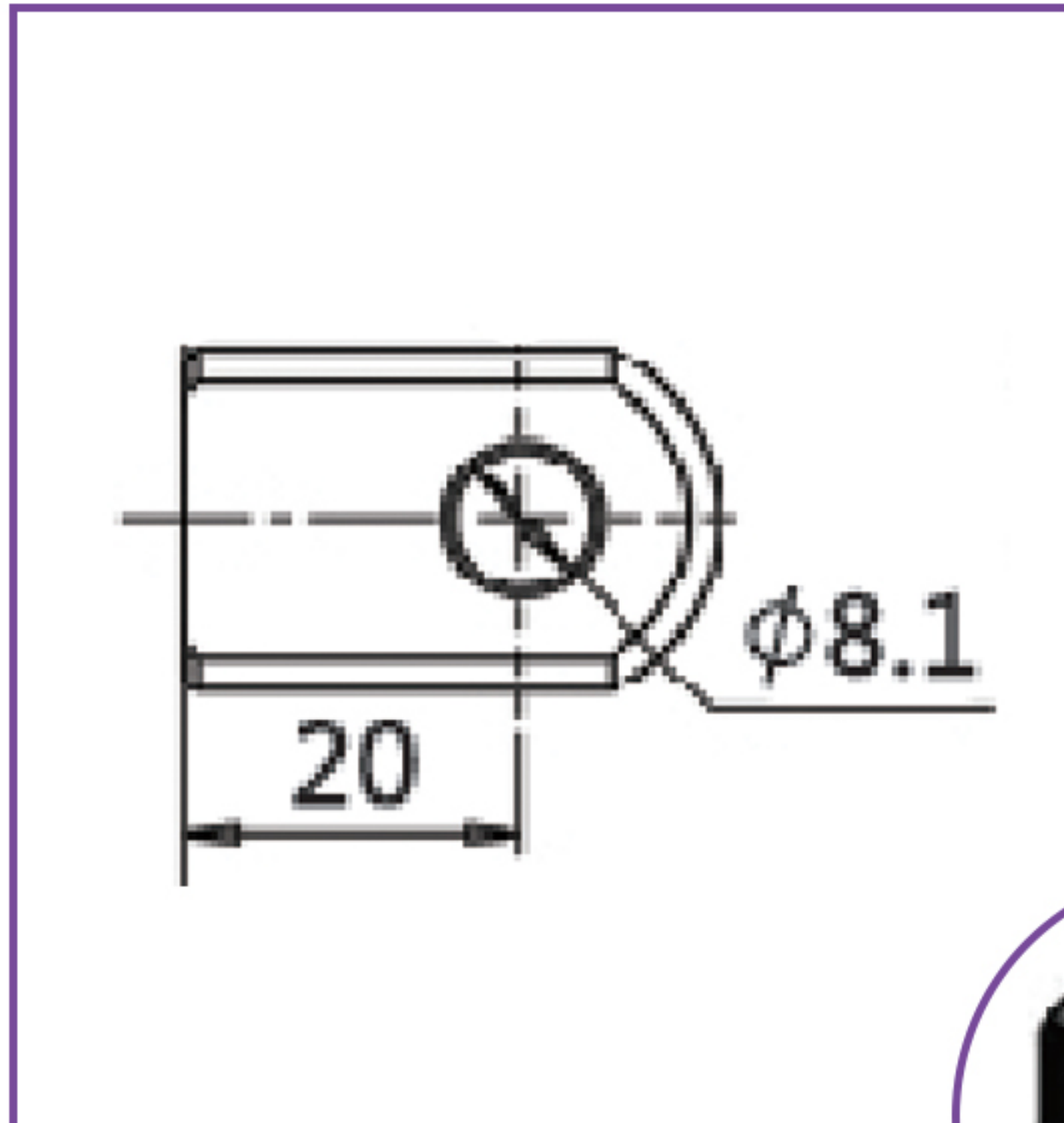

KJT03

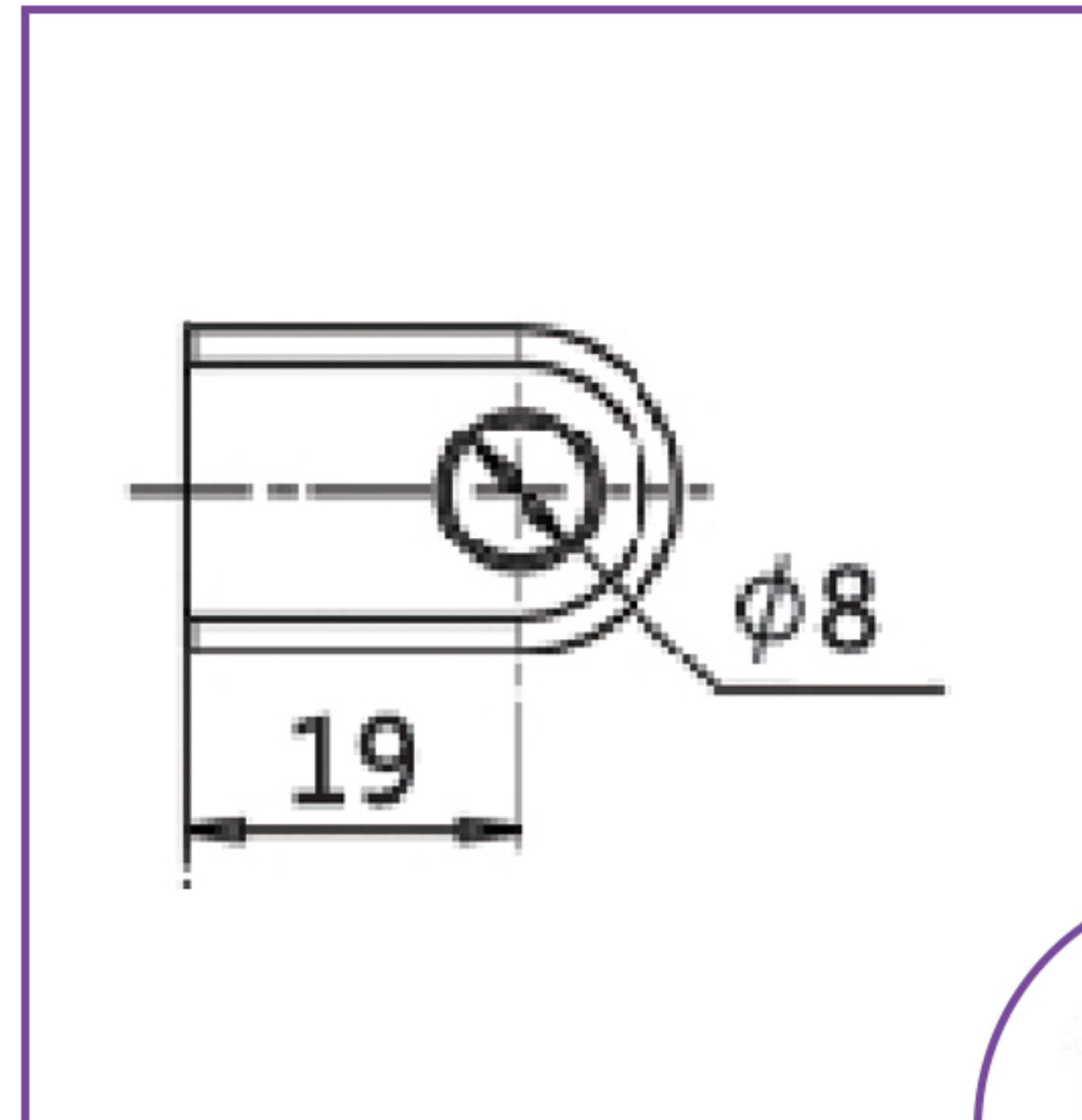

KJT04

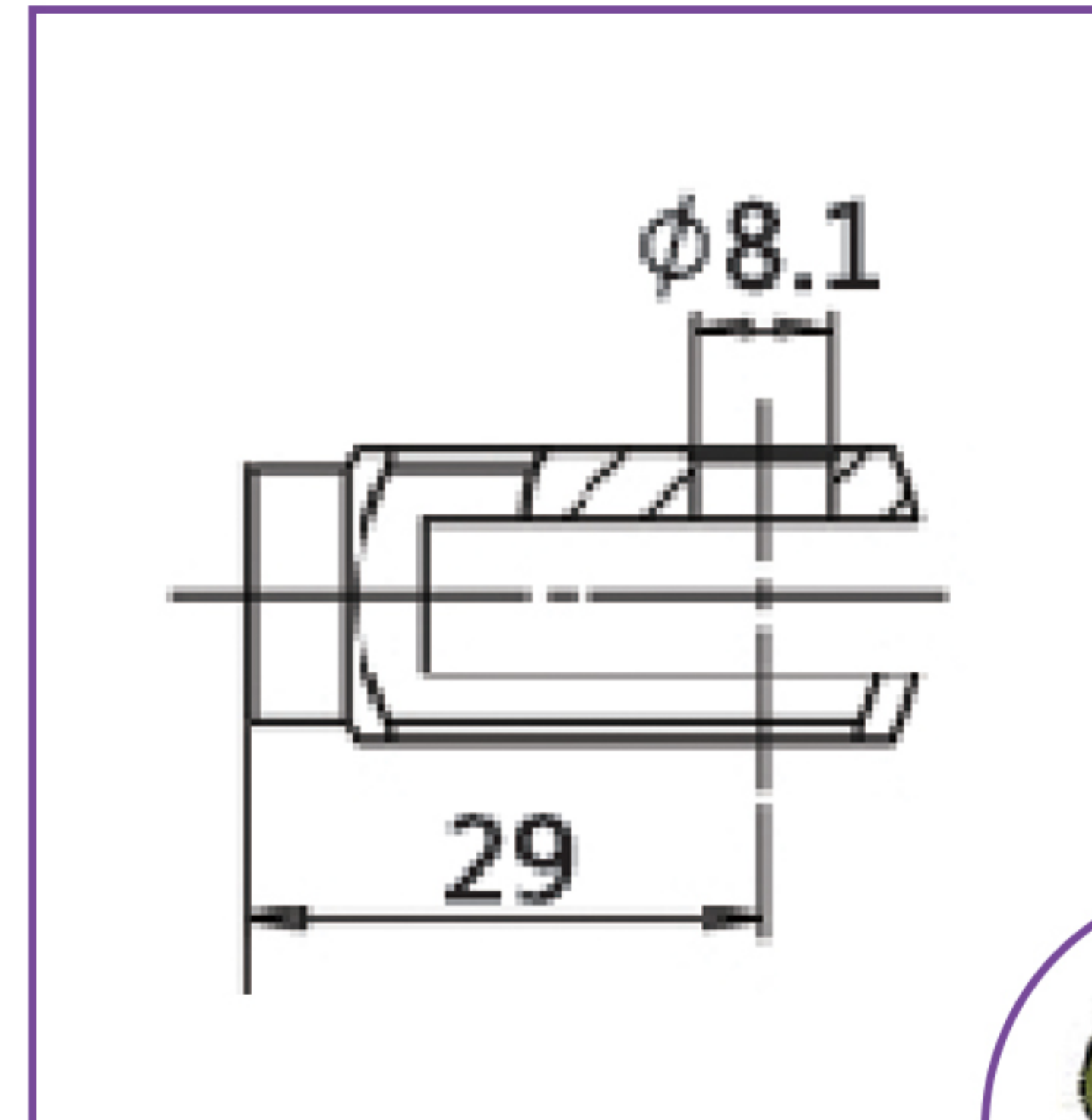
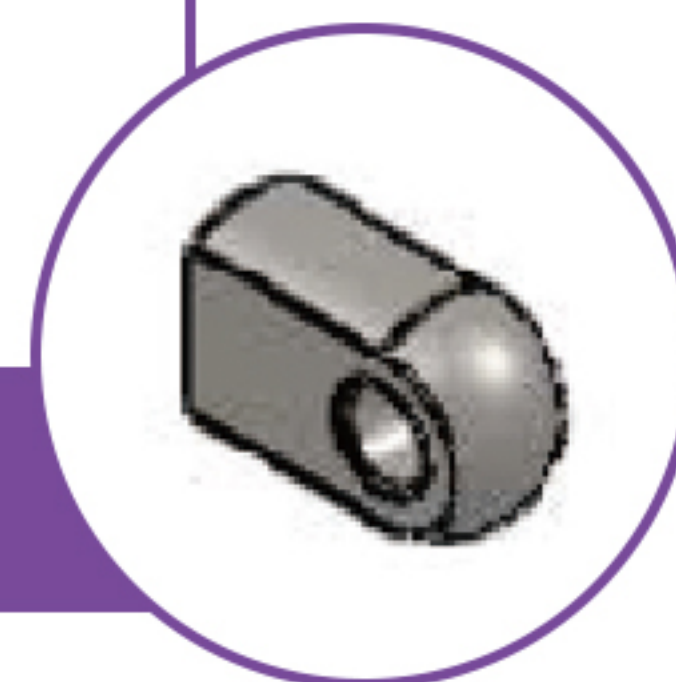

KJT05

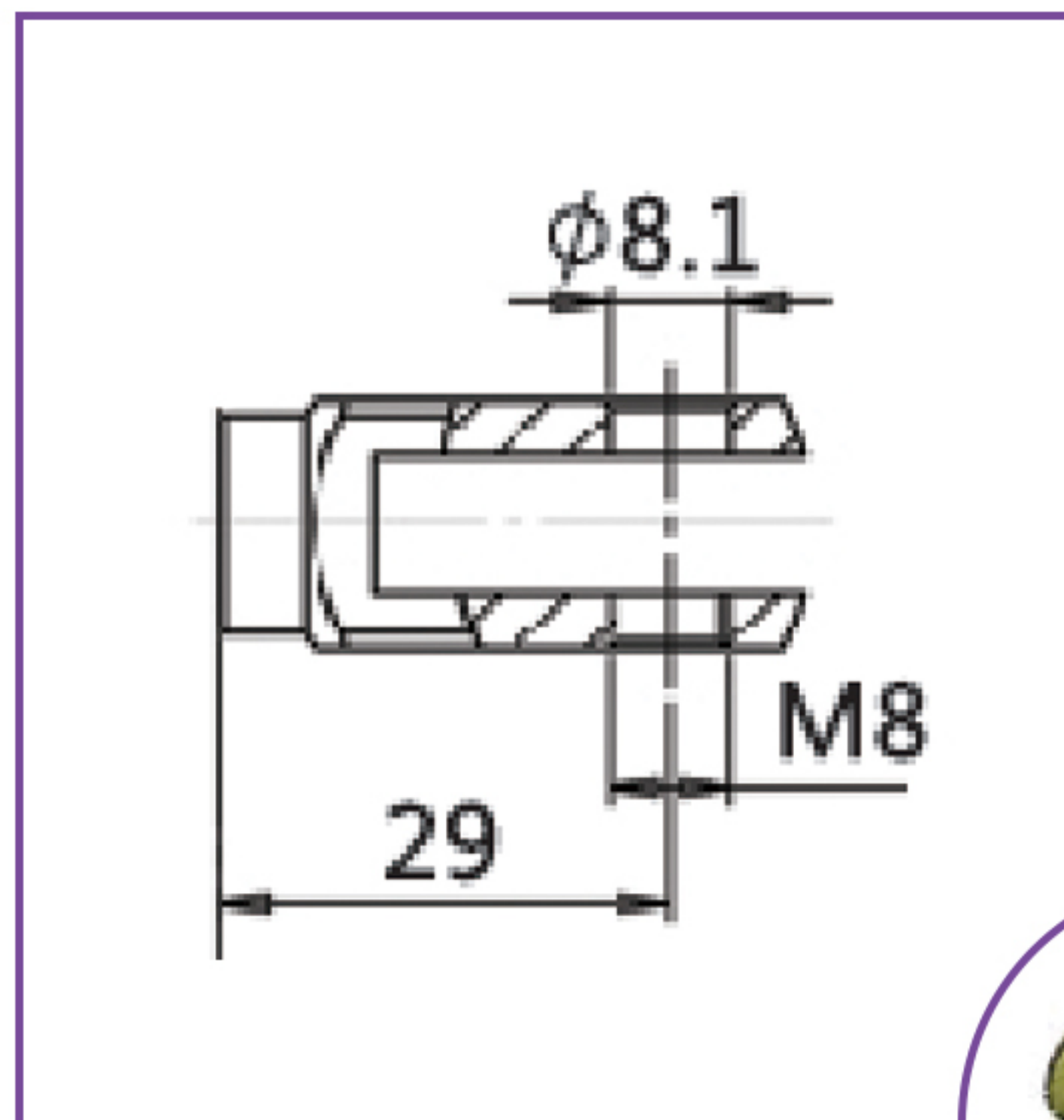

KJT06

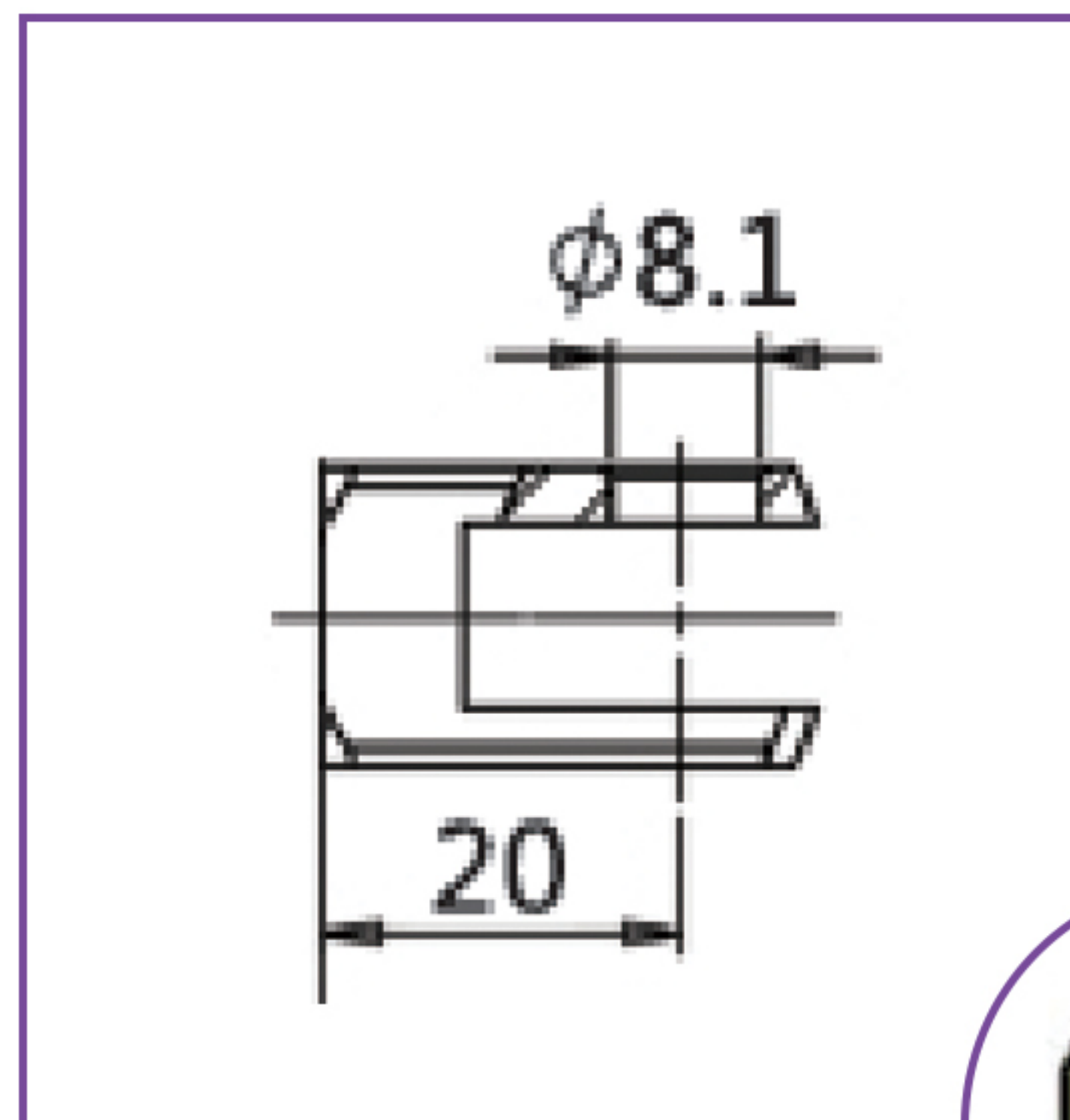
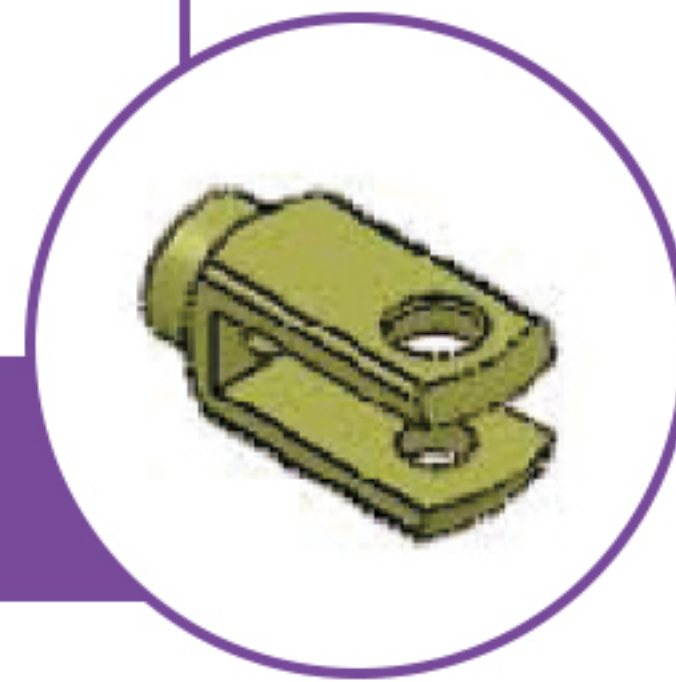

KJT07

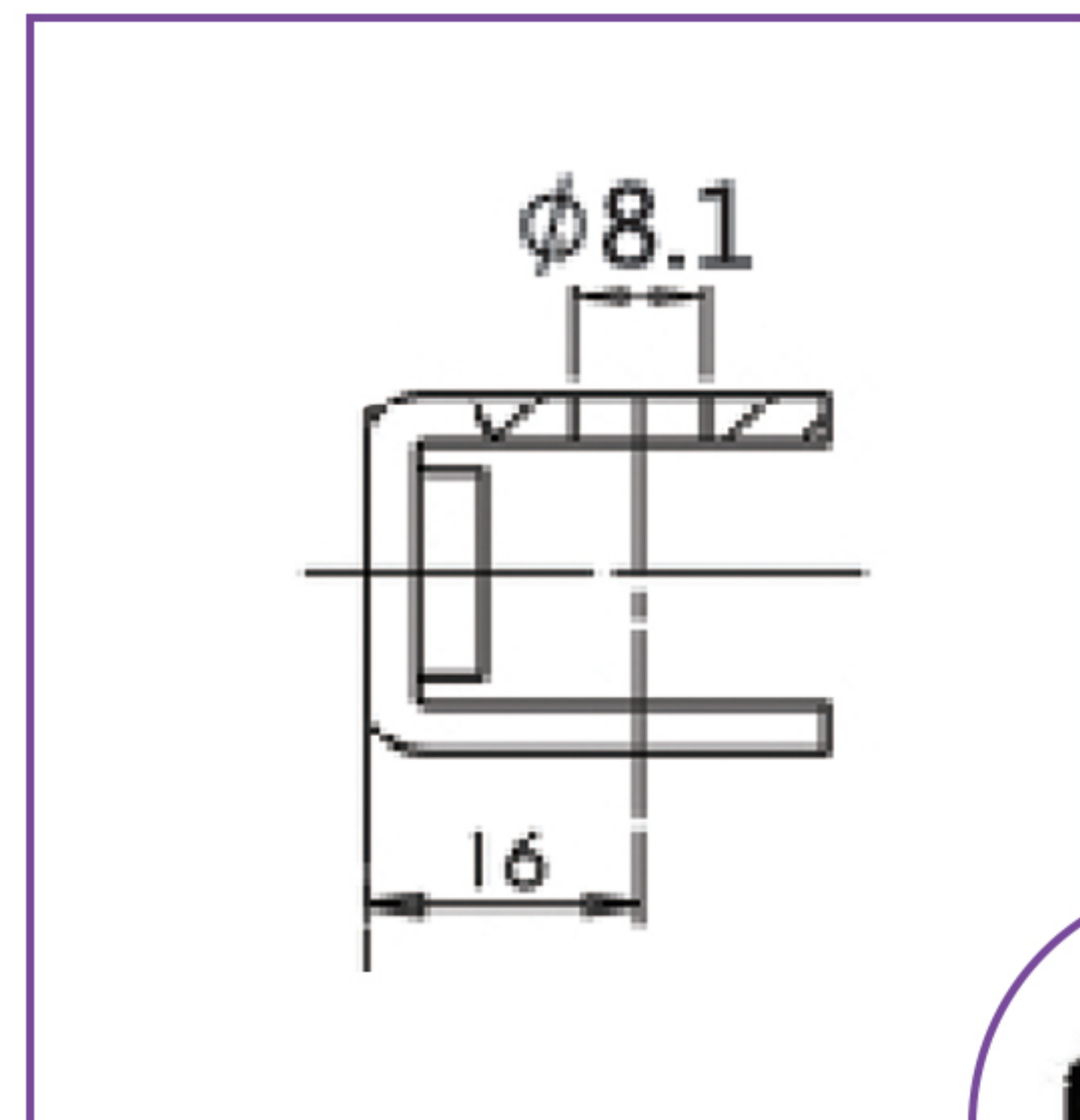

KJT08

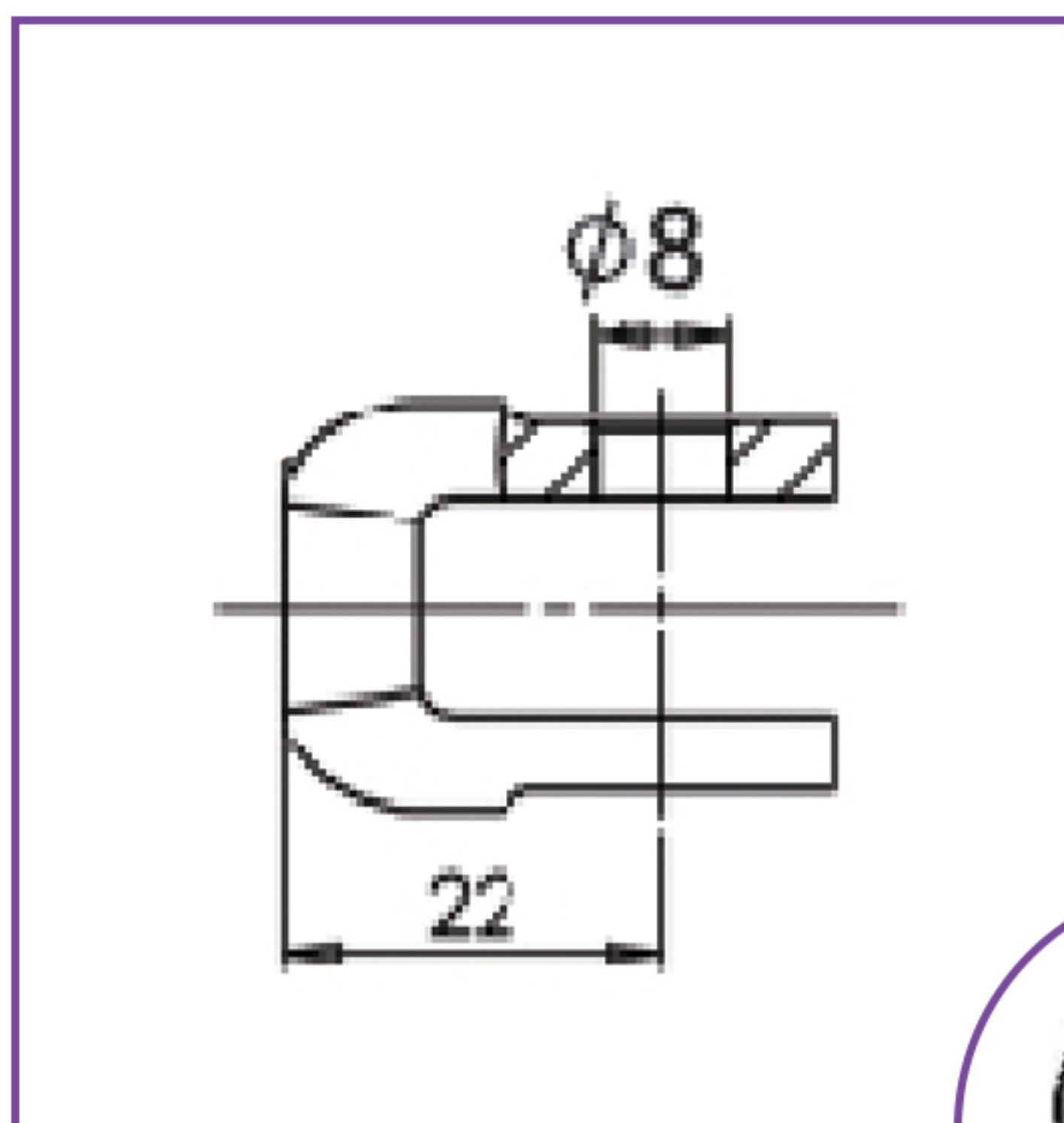

KJT09

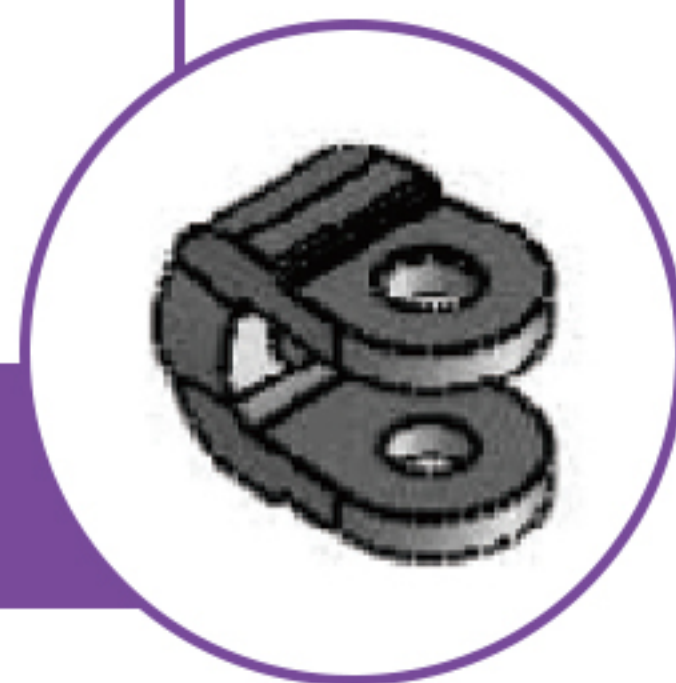



## Borden line, button and handle

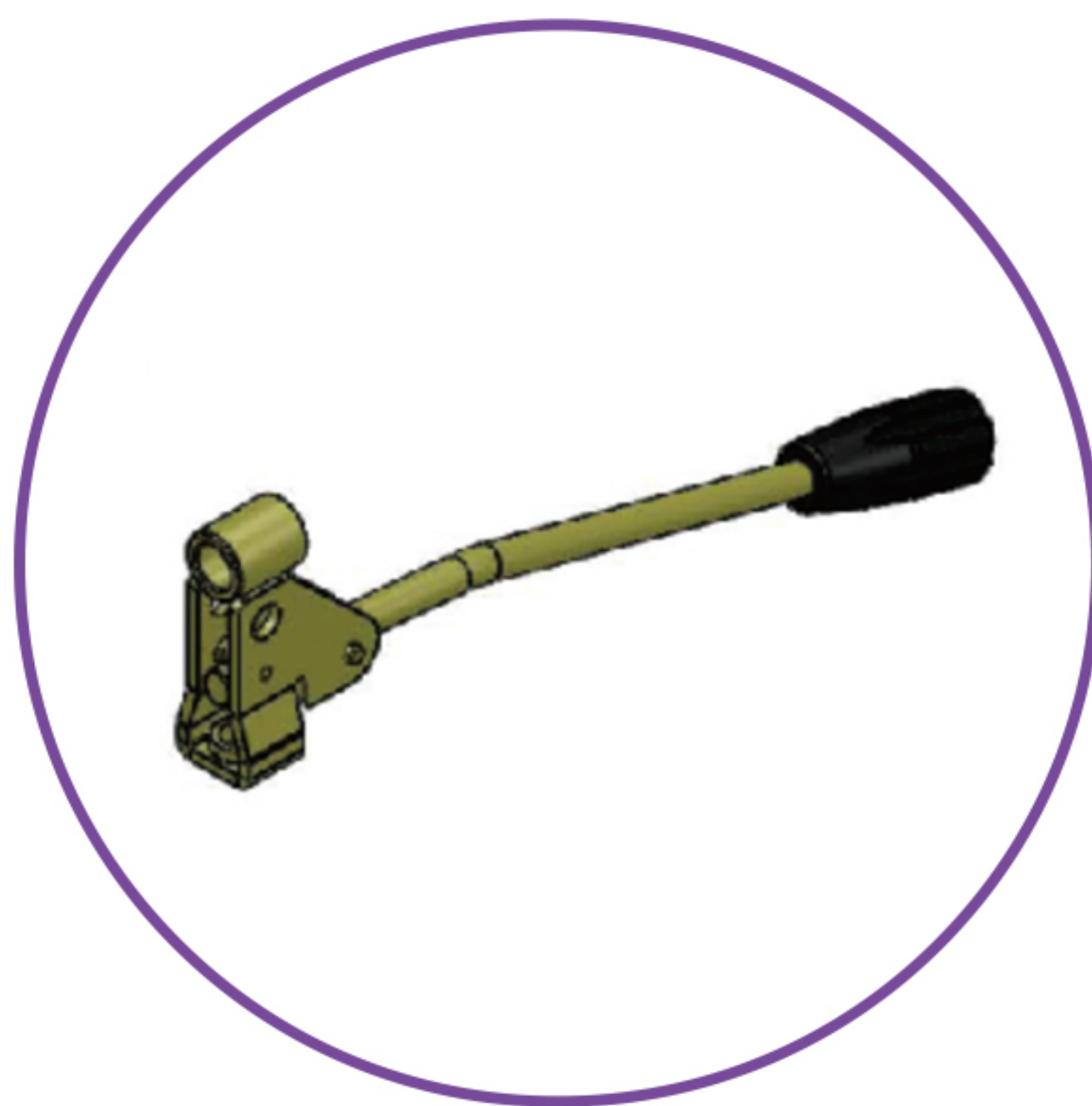
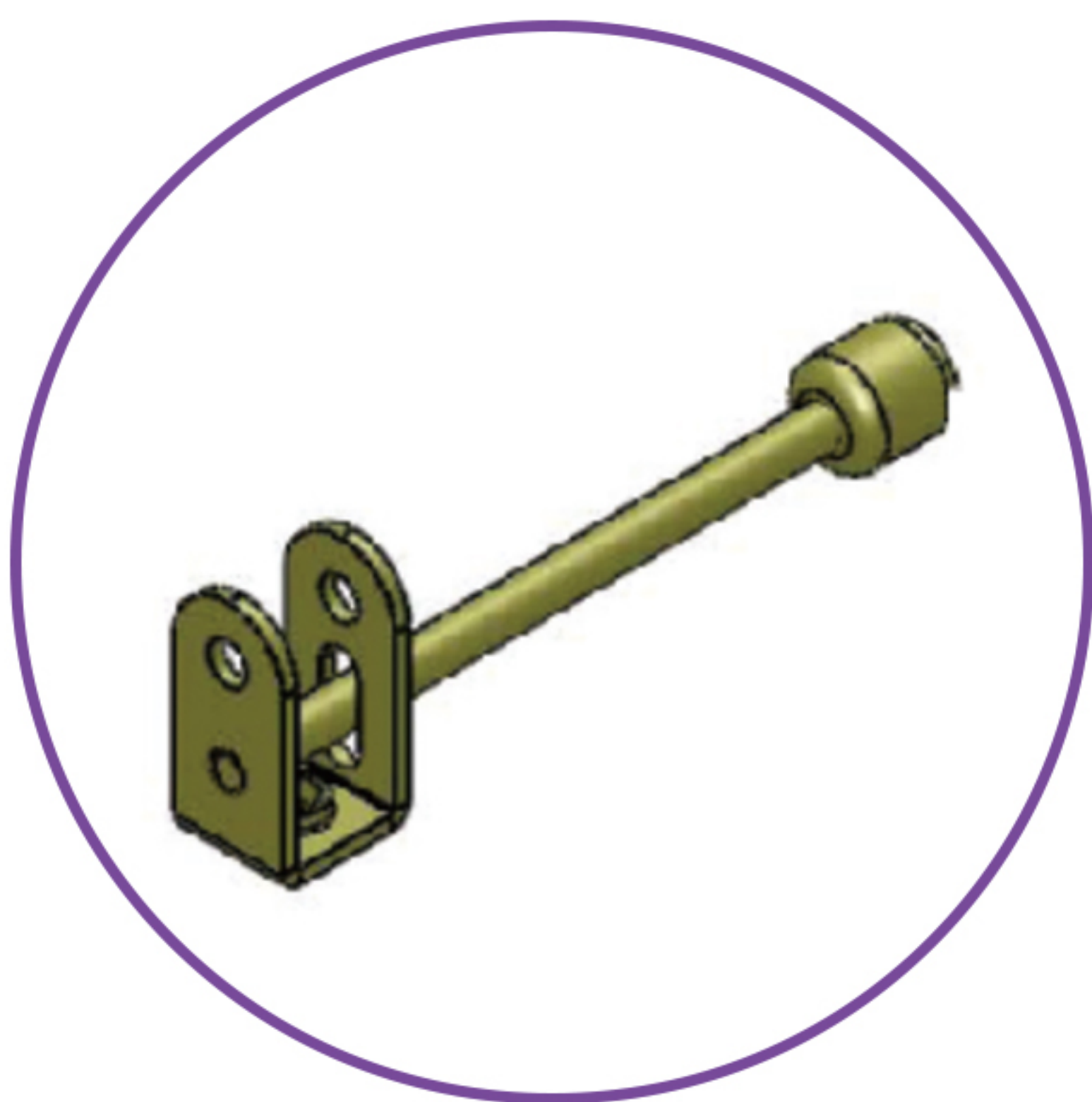
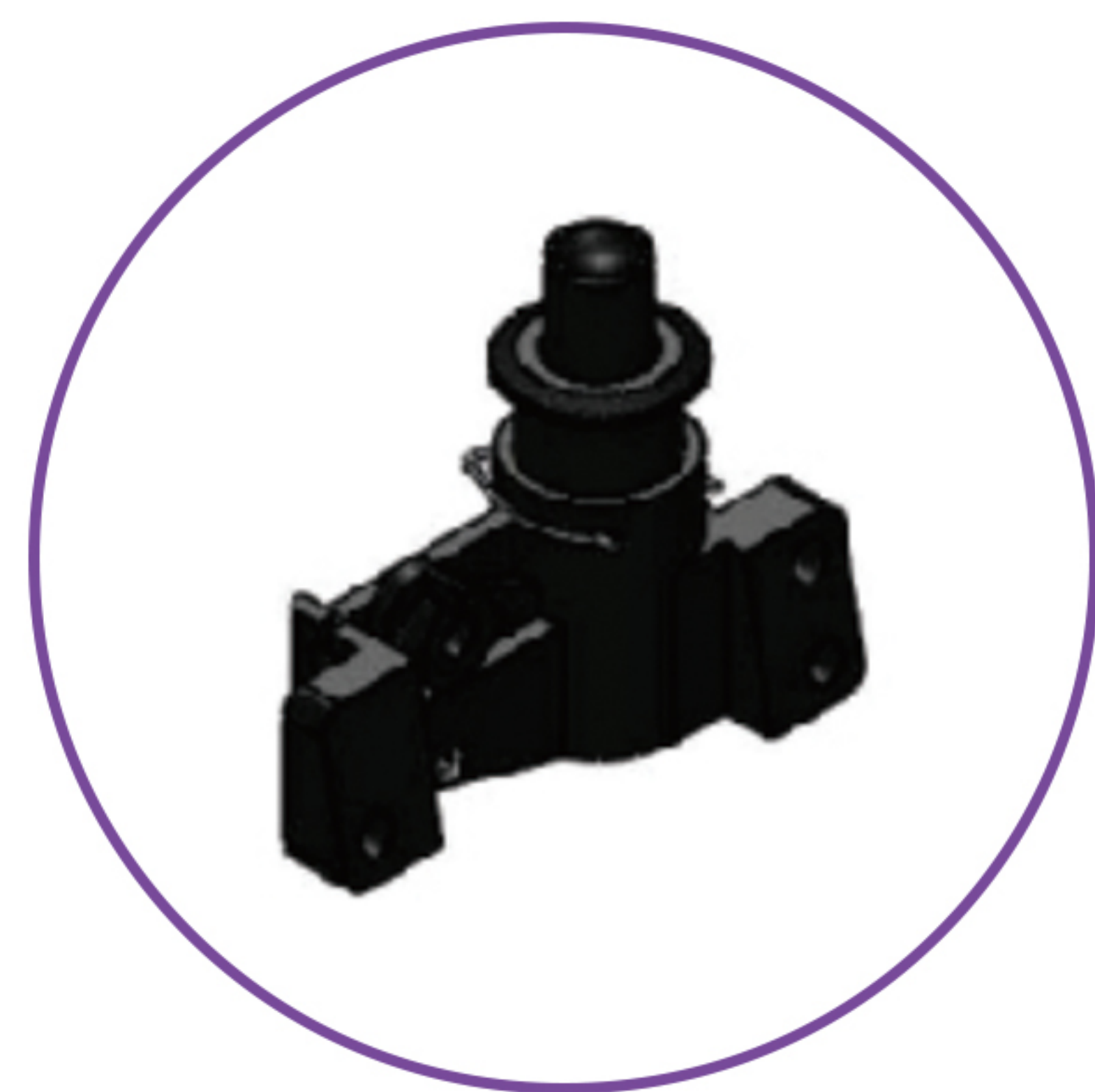
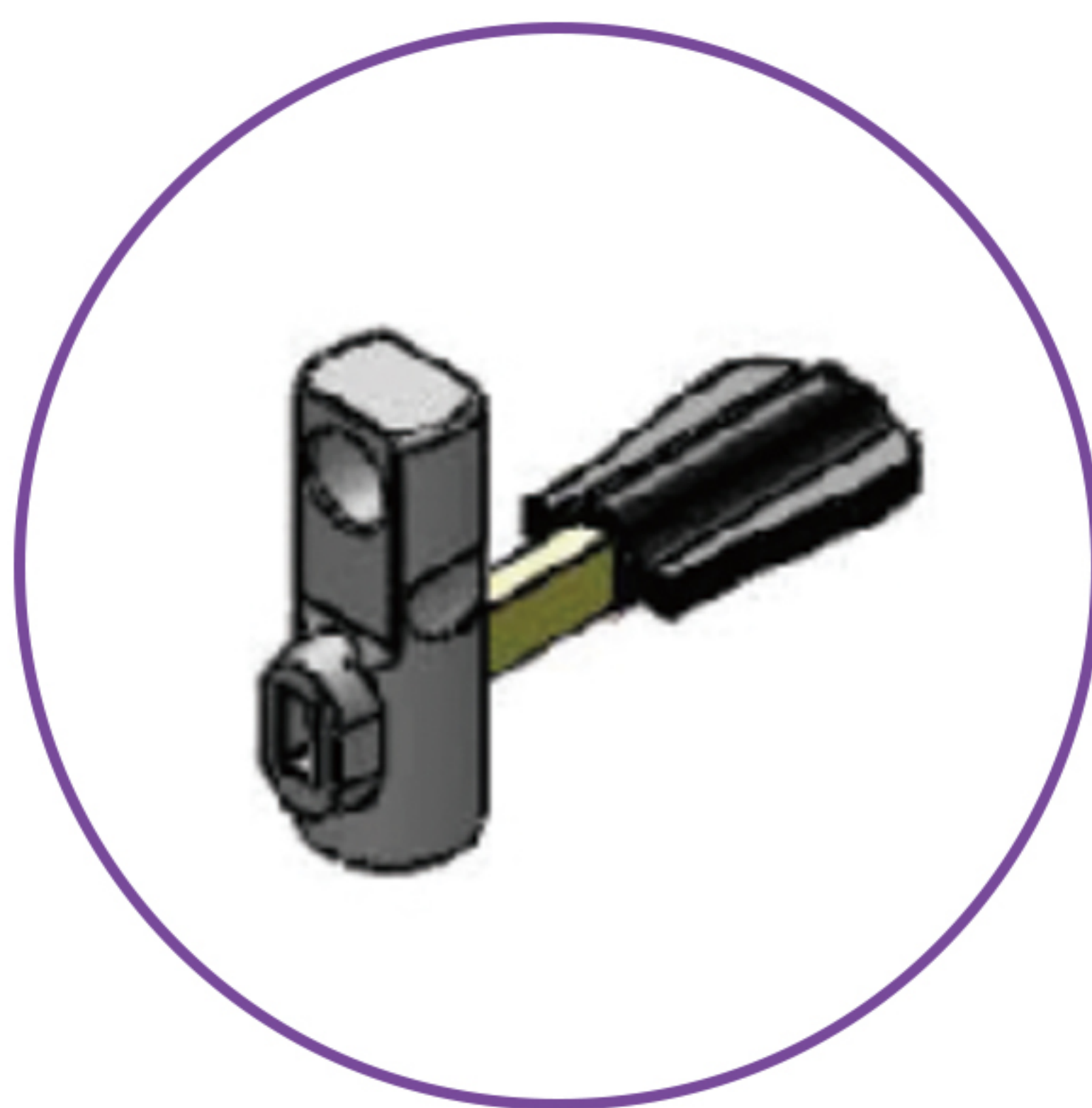





## Delight Your Consumers With Amazing Design

---

### China



Manufacturing Location : Dongguan, Shanghai  
Email:charles.chao@peir-hk.com

### Hong Kong



Head office : 1st Floor, Winbase Centre, 208 Queen's Road  
Central, HongKong  
Email : charles.chao@peir-hk.com

### Mexico



Address: Chihuahua, Mexico  
Email: valeria.gomez@peir-hk.com

### India



Address: Greater Noida, India  
Email: abhishek.pandey@peir-hk.com

### Brazil



Address: São Paulo, Brazil  
Email: info@peir-hk.com